



# **Smart Transmitter/Gas Detector Head**

## **SD-1DOX**

### **(TYPE MED EX)**

#### **Operating Manual**

**(PT2E-179)**

## **RIKEN KEIKI Co., Ltd.**

2-7-6 Azusawa, Itabashi-ku, Tokyo, 174-8744, Japan

Phone : +81-3-3966-1113

Fax : +81-3-3558-9110

E-mail : [intdept@rikenkeiki.co.jp](mailto:intdept@rikenkeiki.co.jp)

Web site : <https://www.rikenkeiki.co.jp/>

## Operating Precautions

This detector is an oxygen deficiency detector that detects oxygen in the air and triggers an oxygen deficiency alarm.

The oxygen deficiency detector is a safety unit, not an analyzer or densitometer which performs quantitative/qualitative analysis/measurement for oxygen.

Please fully understand the following points before using it, so that it can be used properly.

1. The readings of the detector may be fluctuated by environmental (temperature, humidity etc.) changes in the installation site. In addition, if atmosphere pressure correction setting mode is disabled, it fluctuates slightly in response to changes in the air pressure. In particular, be careful of alarm activation when a low air pressure is brought in by typhoon.
2. The alarm must be set within a range where the performance of the detector can be ensured. The standard alarm setpoint value is 18 vol%.
3. If use in safety unit, the analog signal output of the detector must be used for an indicator or external recorder.  
If these outputs are used to control other units, we shall not be responsible for any malfunctions.
4. Contact us for pretreatment systems that you will need for sampling gases from areas of high humidity, high dust concentration, or acidic mist.
5. For maintenance of the detector, it must go through a regular maintenance, including replacement and adjustment of the regular replacement parts as specified in the operating manual.

---

## <Contents>

1 Outline of the Product.....	2
1-1. Preface.....	2
1-2. Purpose of use.....	2
1-3. Definition of DANGER, WARNING, CAUTION and NOTE.....	2
1-4. Method of confirmation for Standards and Explosion proof specification.....	3
2 Important Notices on Safety.....	4
2-1. Danger cases.....	4
2-2. Warning cases.....	5
2-3. Precautions.....	6
2-4. Safety Information.....	7
3 Product Components.....	8
3-1. Main unit and standard accessories.....	8
3-2. Names and functions for each part.....	9
3-3. Block diagram.....	10
4 How to Use.....	11
4-1. Before using the gas detector.....	11
4-2. Precautions for installation sites.....	11
4-3. Precautions for system designing.....	12
4-4. How to install.....	13
4-5. Installation procedure.....	15
4-6. How to wire.....	18
4-7. How to tube.....	22
5 How to Operate.....	21
5-1. Preparation for start-up.....	21
5-2. Basic operating procedures.....	21
5-3. How to start the gas detector.....	22
5-4. Modes.....	23
5-5. Maintenance mode(User).....	24
5-6. How to exit.....	26
6 Operations and Functions.....	27
6-1. Alarm activation.....	27
6-2. Fault alarm activation.....	28
6-3. Warning activation.....	28
6-4. External output operation.....	29
6-5. Other functions.....	30
7 Maintenance.....	31
7-1. Maintenance intervals and items.....	31
7-2. Maintenance mode (Regular Maintenance).....	33
7-3. Calibration method.....	33
7-4. Parts replacement.....	44
8 Storage, Relocation and Disposal.....	45
8-1. Procedures to store the gas detector or leave it for a long time.....	45
8-2. Procedures to relocate the detector or use it again.....	45
8-3. Disposal of products.....	45
9 Troubleshooting.....	46
10 Product Specifications.....	48
10-1. List of specifications.....	48
10-2. Detection principle.....	51
11 Definition of Terms.....	52

## 1

# Outline of the Product

## 1-1. Preface



Thank you for choosing our smart transmitter/gas detector head SD-1DOX(TYPE MED EX). Please check that the model number of the product you purchased is included in the specifications on this manual.

This manual explains how to use the detector and its specifications. It contains information required for using the gas detector properly. Not only the first-time users but also the users who have already used the product must read and understand the operating manual to enhance the knowledge and experience before using the detector.

## 1-2. Purpose of use

- This detector is a fixed type gas detector head that detects oxygen and performs the alarm activation when the gas concentration is over the setting value.
- The detector detects abnormalities in the air caused by presence of gases or other reasons (leak) with the built-in gas sensor. The concentrations of detected gases are displayed on the seven-segment LED.
- The detector outputs gas concentration in 4 – 20 mA.
- An external pump etc. outside the detector introduces gas to perform gas detection.
- The detector has HART communication function. The HART communication function can be used only during maintenance.
- The detector is a safety unit, not an analyzer or densitometer which performs quantitative/qualitative analysis/measurement for gases. Please fully understand the features of the detector before using it, so that it can be used properly.

## 1-3. Definition of DANGER, WARNING, CAUTION and NOTE

 <b>DANGER</b>	This message indicates that improper handling may cause serious damage on life, health or assets.
 <b>WARNING</b>	This message indicates that improper handling may cause serious damage on health or assets.
 <b>CAUTION</b>	This message indicates that improper handling may cause minor damage on health or assets.
<b>NOTE</b>	This message indicates advice on handling.

# 1-4. Method of confirmation for Standards and Explosion proof specification

This instrument has some specification depends on standard and explosion proof certificate. Please confirm the detector specification before using. Please refer Declaration of Conformity that is at the end of this manual if you have CE marking type. You can confirm instrument specification to see name plate as follows.

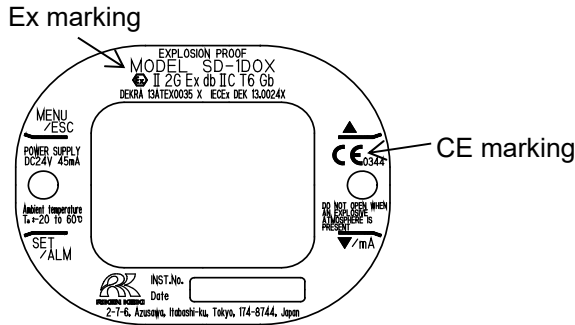

ATEX/IECEEx, CE marking type name plate

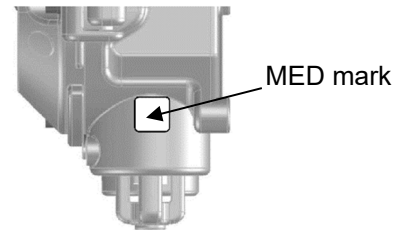

MED mark position

## 2

# Important Notices on Safety

## 2-1. Danger cases



### DANGER

#### About explosion-proof

- The window plate material is a polycarbonate resin. Do not use organic solvents and alkali types (liquid or vapor). It may cause the color and shape of the window plate to be changed.
- Do not open the lid when applying current.
- Do not attempt to repair the detector.
- For the lid, use hexagon socket head bolts specified by RIKEN KEIKI.
- Do not apply a strong force or shock to the window plate. The explosion-proof performances may be deteriorated due to damages. The explosion protection condition for the detector is "low (2J)" possibility of mechanical damage.
- Ambient temperature: -20 to +60°C  
(The ambient temperature on explosion-proof certification is described above and it indicates the temperature range which can maintain the explosion-proof performance and not the product performance, see "10-1. List of specifications" for details.)
- Do not replace parts at your sole discretion but contact RIKEN KEIKI if the transparent window has a crack or the explosion-proof joint surface is abnormal, or the clamping screw or bolt is changed, lost etc.
- Do not repair the explosion-proof joint surface.
- Be careful not to hit sharp tools against the window plate.
- Nitrile rubber (NBR) is used for the cable gland component. The presence of organic solvents and alkalis (liquid or vapor) in the measurement environment may compromise the explosion-proof integrity.

## 2-2. Warning cases



### WARNING

#### Power supply

Before turning on the detector, always check that the voltage is properly applied. Do not use an unstable power supply because it may cause malfunctions.

#### Need of grounding circuit

Do not cut the grounding circuit or disconnect the wire from the grounding terminal.

#### Defects in protective functions

Before starting the detector, check the protective functions for defects. When seeming defects are found in the protective functions, such as protective grounding, do not start the detector.

#### External connection

Before connecting the detector to the external control circuit, securely connect it to a protective grounding circuit.

#### Tubing

The detector is designed to draw gases around it under the atmospheric pressure. Be sure that excessive pressure is not applied to the sampling inlet and outlet (GAS IN, GAS OUT) of the detector. Detected gases must be exhausted from the detected gas exhausting outlet (GAS OUT) to which an exhaust tube is connected, to a point regarded as a safe place.

#### Span adjustment(AIR adjustment) in atmosphere

When the span adjustment(AIR adjustment) is performed in the atmosphere, check the atmosphere for freshness before beginning the adjustment. If interference gases exist, the adjustment cannot be performed properly, thus leading to dangers when the oxygen concentration fluctuates.

#### Response to gas alarm

Issuance of a gas alarm indicates that there are extreme dangers. Take proper actions based on your judgment.

## 2-3. Precautions



### CAUTION

**Do not use a transceiver near the detector.**

Radio wave from a transceiver or other radio wave transmitting device near the detector or its cables may disturb readings. If a transceiver or other radio wave transmitting device is used, it must be used in a place where it disturbs nothing.

**To restart the detector, wait for five seconds or more before doing it.**

Restarting the detector in less than five seconds may cause errors.

**Verify that the flow rate corresponds to the specified flow rate before using the detector.**

If it does not correspond to the specified flow rate, gas detection cannot be performed properly. Check whether the flow rate is unstable or lost.

**Attach the dust filter before using the detector.**

Before using the detector, attach the specified filter to prevent disturbances by possible gas adsorption or air dust.

A dust filter to be used varies depending on the gas to be detected. For more information on dust filters, please contact RIKEN KEIKI.

**Observe the operating restrictions to prevent condensation inside the tube.**

Condensation formed inside the tube causes clogging or gas adsorption, which may disturb accurate gas detection. Thus, condensation must be avoided. In addition to the installation environment, carefully monitor the temperature/humidity of the sampling point to prevent condensation inside the tube. In particular, when detecting a gas which is dissolved into water and corrodes contacted materials, such as a strong acid gas, the gas is undetectable and furthermore may corrode internal parts. Please observe the operating restrictions.

**Do not use the external output of the detector to control other units.**

This is not a control unit. It is not allowed to use the external output of the detector to control other units.

**Do not disassemble/modify the detector, or change the settings if not necessary.**

Disassembling/modifying the detector will invalidate the warranty of the performance. Changing the settings without understanding the specifications may cause alarm malfunctions. Please use the detector properly in accordance with the operating manual.

**Avoid applying organic solvents and others to the window plate for a long time.**

The window plate material is a polycarbonate resin. When organic solvents (liquid or highly-concentrated vapor) and others are applied to the plate for a long time, its color and shape may be changed.

**Never fail to perform a regular maintenance.**

Since this is a safety unit, a regular maintenance must be performed to ensure safety. Continuing to use the detector without performing a maintenance will deteriorate the sensitivity of the sensor, thus resulting in inaccurate gas detection.



## 2-4. Safety Information

### Necessary information for explosion proof construction of Model SD-1DOX.

The Model SD-1DOX is a fixed mount, continuous-monitoring detector head and provides a 4-20mA signal which indicates the target gas reading for use by a gas monitoring controller, recording device, or programmable controller.

#### Technical Data

(Protection Method)	Flameproof enclosure “d”
(Certificate Numbers)	IECEX DEK 13.0024X DEKRA 13ATEX0035 X
(Group)	II
(Category)	2 G
(Type of Protection and Marking code)	Ex db IIC T6
(Equipment Protection Level)	Gb
(Ambient Temperature)*	-20°C to +60°C
(Electrical Data)	Supply voltage: 24VDC±10% 45mA Output signal (4 to 20 mA): 24VDC 22mA
(Applicable Standard)	IEC 60079-0: 2017, IEC 60079-1: 2014-06 EN IEC 60079-0: 2018, EN 60079-1: 2014
(Manual Number)	PT2E-179

\* The ambient temperature on explosion-proof certification is described above and it indicates the temperature range which can maintain the explosion-proof performance and not the product performance, see “10-1. List of specifications” for details.

#### Installation

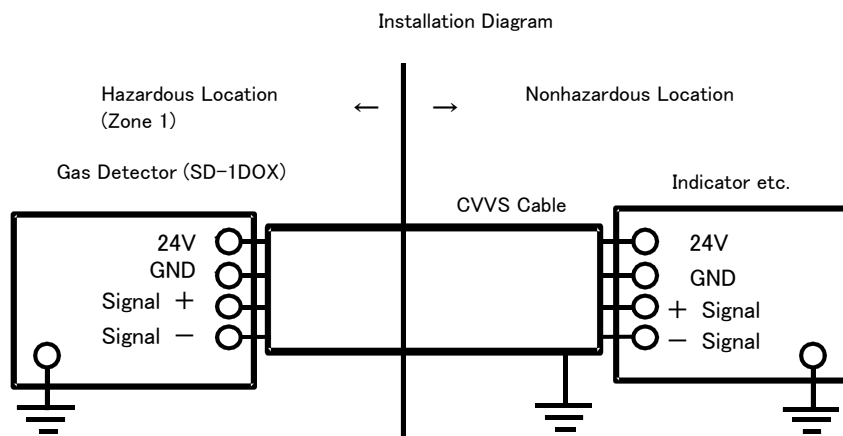

3

# Product Components

## 3-1. Main unit and standard accessories

<Main Unit> (including a cable gland or an adapter)

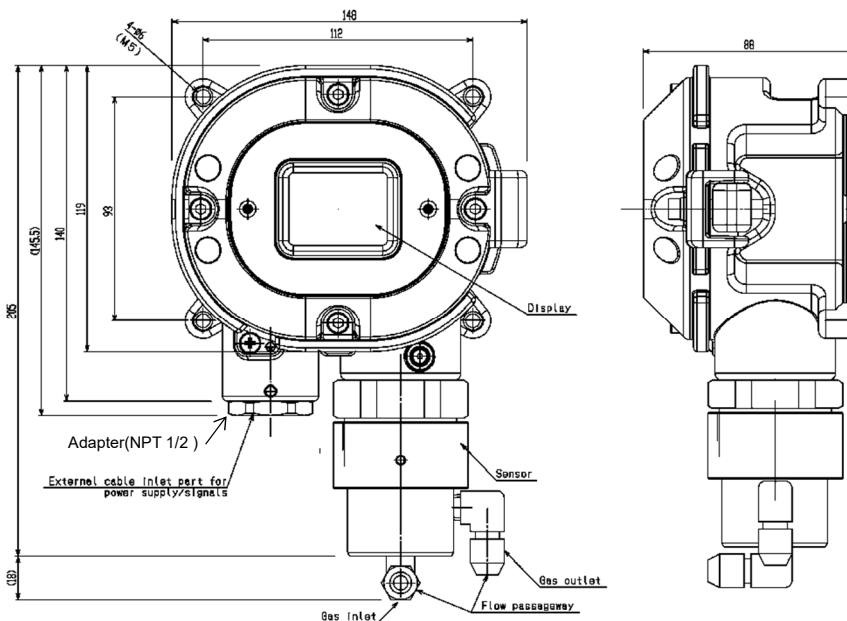

<Standard Accessories>

- Operating manual..... one
- Dedicated handling lever ..... one
- Dedicated control key..... The supplied quantity depends on the number of units to be delivered.

1 to 10 units	one
11 to 20 units	two
21 to 50 units	three
over 51 units	four



### CAUTION

Use the supplied dedicated control key to operate the detector. If products other than these accessories are used, key operations cannot be accepted properly.

Note that the control key is made of extremely strong magnet. Putting it close to a magnetic product, such as a credit card and ID card, may damage the stored data.

## 3-2. Names and functions for each part

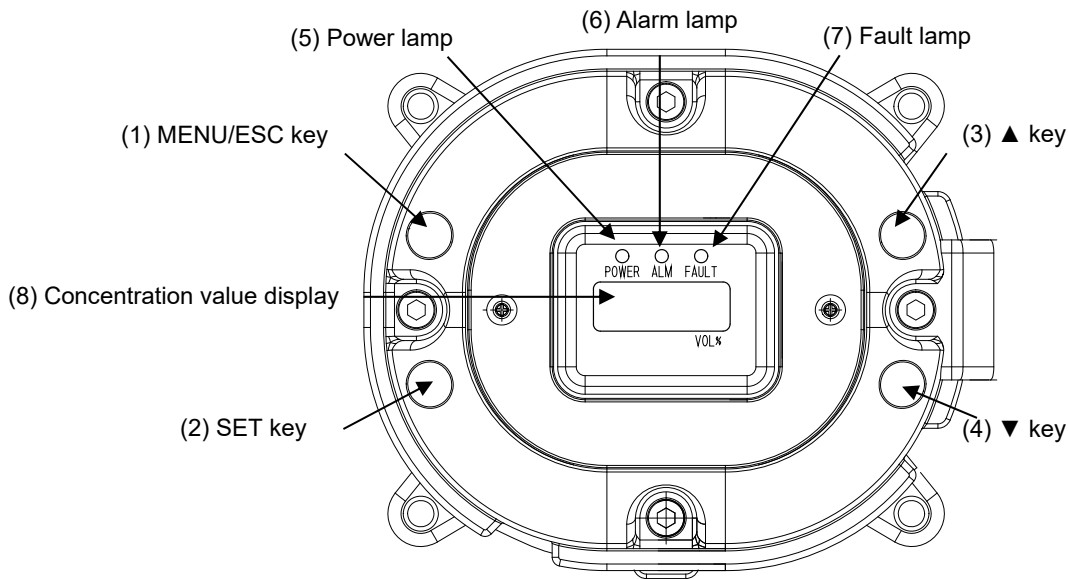

(1)	MENU/ESC key	Used to enter the maintenance mode. It is also used to cancel in a specific mode.
(2)	SET key	It is used for value confirmation and so on in a specific mode.
(3)	▲ key	Used to switch menus or change a value (UP).
(4)	▼ key	Used to switch menus or change a value (DOWN).
(5)	Power lamp	Power lamp. Detection mode: It lights up in green. Maintenance mode: It blinks in green.
(6)	Alarm lamp	Alarm lamp. It lights up in red when the alarm setpoint value is reached.
(7)	Fault lamp	Fault lamp. It lights up in yellow when an abnormality is detected in the detector.
(8)	Concentration value display	Display the gas concentration and so on.

### 3-3. Block diagram

<Electric Diagram>

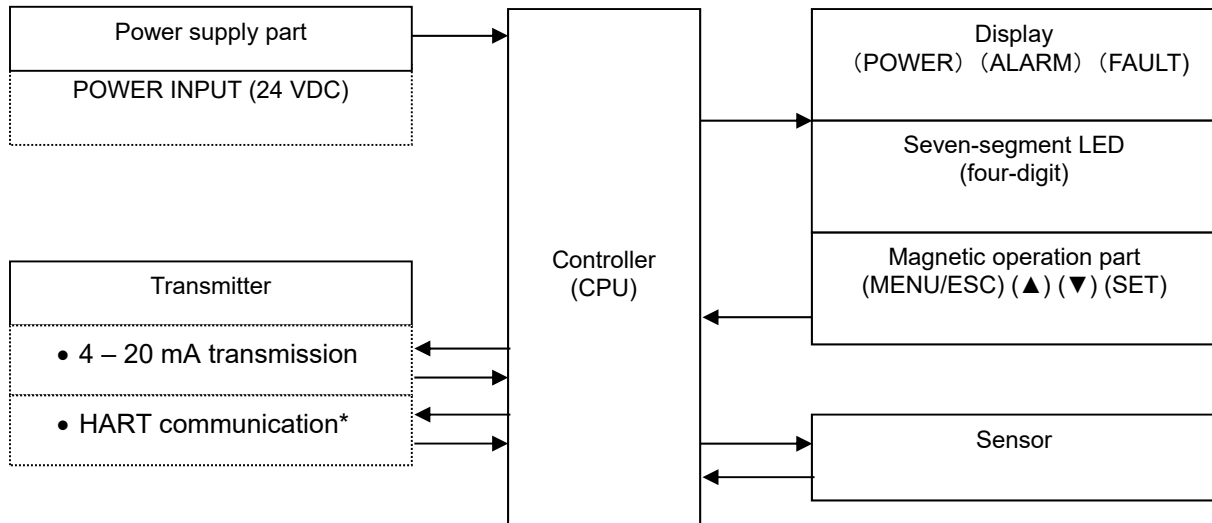

\*It is used only for maintenance.

---

## 4

---

# How to Use

### 4-1. Before using the gas detector

Not only the first-time users but also the users who have already used the detector must follow the operating precautions.

Ignoring the precautions may damage the gas detector, resulting in inaccurate gas detection.

#### NOTE

• Regarding the use, setting, and maintenance of gas detectors, it is recommended to refer to standards that are appropriate for each country's regulations. Example) IEC 60079-29-2, EN 60079-29-2, NFPA 70.

### 4-2. Precautions for installation sites



#### CAUTION

This is a precision device. Because the detector may not provide the specified performance in some places (environments), check the environment in the installation point, and then take appropriate actions if necessary.

Because the detector plays an important role for safety and disaster prevention, as many units of the detector as needed must be installed in appropriate points.

Because points where gases leak and remain easily are different depending on the types of gases and the working areas, please decide carefully on installation points and the number of units to be installed.

Do not install the detector in a place with vibrations or shocks.

The detector consists of sensitive electronic parts. The detector must be installed in a stable place without vibrations or shocks and it cannot drop.

Do not install the detector in a place exposed to water, oil or chemicals.

When selecting installation points, avoid a place where the detector is exposed to water, oil or chemicals.

Do not install the detector in a place where the range of operating temperatures is exceeded.

The detector must be installed in a stable place where the operating temperature is maintained and does not change suddenly.

\*For operating temperature range, see "10-1. List of specifications" for details.

Do not install the detector in a place exposed to direct sunlight or sudden changes in the temperature.

When selecting installation points, avoid a place where it is exposed to direct sunlight or radiant heat (infrared rays emitted from a high-temperature object), and where the temperature changes suddenly. Condensation may be formed inside the detector, or the detector cannot adjust to sudden changes in the temperature.

**Keep the detector (and its cables) away from noise source devices.**

When selecting installation points, avoid a place where high-frequency/high-voltage devices exist.

**Do not install the detector in a place where maintenance of the detector cannot be performed or where handling the detector involves dangers.**

Regular maintenance of the detector must be performed.

Do not install the detector in a place where the machinery must be stopped when maintenance is performed in its inside, where parts of the machinery must be removed to perform maintenance, or where the detector cannot be removed because tubes or racks prevent access to it. Do not install the detector in a place where maintenance involves dangers, for example, near a high-voltage cable.

**Do not install the detector in machinery which is not properly grounded.**

Before installing the detector in machinery, the machinery must be grounded properly.

**Do not install the detector in a place where interference gases exist around it.**

The detector must not be installed in a place where interference gases exist around it. In particular, areas with carbon dioxide concentration over 15 vol% may influence the detector readings.

## 4-3. Precautions for system designing



### CAUTION

An unstable power supply and noise may cause malfunctions or false alarms.

The descriptions in this section must be reflected on the designing of a system using the detector.

**Using a stable power supply**

The external output and alarm contact of the detector may be activated when the power is turned on, when momentary blackout occurs, or while the system is being stabilized. In such cases, use a UPS (uninterruptible power supply), or take appropriate actions on the receiving side.

The detector must be provided with the following power supply.

Power supply voltage	24 VDC±10%: Terminal voltage of the detector	
Allowed time of momentary blackout	Up to 10 milliseconds (To recover from the momentary blackout for 10 milliseconds or more, restart the detector.)	<u>Example of actions</u> To ensure continuous operation and activation, install a UPS outside the detector.
Others	Do not use it with a power supply of large power load or high-frequency noise.	<u>Example of actions</u> Use a line filter to avoid the noise source if necessary.

**Introducing protective measures against lightning**

If cables are installed outside the factory/plant, or if internal cables are installed in the same duct as the cables coming from outside the factory/plant, "lightning" will cause problems. Because lightning acts as a large emission source while cables act as a receiving antenna, devices connected to the cables may be damaged.

Lightning cannot be prevented. Cables installed in a metal conduit or under the ground cannot be completely protected from inductive lightning surge caused by lightning. Although complete elimination of disasters caused by lightning is impossible, the following protective measures can be taken.

Protection against lightning	<p>Take appropriate measures in accordance with the importance of the facilities and the environment.</p> <ul style="list-style-type: none"> <li>Provide protection by a lightning arrester (cable arrester). (Although inductive lightning surge can be transmitted through the cable, it is prevented by installing a lightning arrester before the field devices and central processing equipment. For information on how to use a lightning arrester, please contact the manufacturer.)</li> </ul>
Grounding	In addition to lightning, there are more sources of surge noise. To protect units from these noise sources, the units must be grounded.

- \* The lightning arrester has a circuit to remove a surge voltage which damages field devices, so that signals may be attenuated. Before installing a lightning arrester, verify that it works properly.

## 4-4. How to install

### <Installation Dimensions and Maintenance Space>

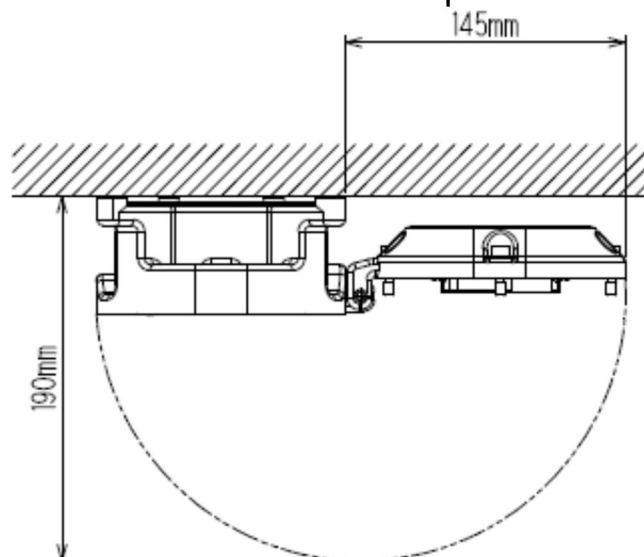

The following installation requirements must be met to install the detector.

- Attach the detector on the wall and others using four M5 screws.
- Tighten the hexagon socket head cap screws fixing the lid and the main body with the tightening torque of  $215.6 \pm 24.5 \text{ N} \cdot \text{cm}$ .
- When closing the lid of the detector, please wipe the screw and the mating surface of the main body and the lid, and apply our company-specified grease.
- To maintain compliance to EN 50104, ensure orientation is within  $\pm 90^\circ$  of normal on installation.



### CAUTION

Do not install the detector in a place where maintenance of the detector cannot be performed or where handling the detector involves dangers.

Regular maintenance of the detector must be performed.

Do not install the detector in a place where the machinery must be stopped when maintenance is performed in its inside, where parts of the machinery must be removed to perform maintenance, or where the detector cannot be removed because tubes or racks prevent access to it. Do not install the detector in a place where maintenance involves dangers, for example, near a high-voltage cable.

**WARNING**

- Install the detector head in the specified direction. Installing it in a wrong direction may cause abnormal readings.
- Install the detector while giving due consideration to the conditions for the detection area. Normally, when the detector is used to detect oxygen deficiency, the detector head should be installed at a face level.
- When there is a risk of oxygen deficiency due to a gas heavier than the air (CO<sub>2</sub> etc.), install the detector in consideration for the specific gravity of the gas.
- Do not install the detector in a damp place where condensation occurs. Water drops formed on the sensor may cause abnormal detection.

**NOTE**

- Hexagon socket head cap screws with strength class "A2-70" are used. When you lost or replace it, we recommend that you ask our local sales office nearest you.
- Our company-specified grease : BARRIERTA JFE 552 (NOK KLUBER made)  
If you can not prepare the specified grease, please use one that meets the following requirements.
  1. Those not cured by deterioration
  2. Those containing no volatile solvent
  3. Those which do not cause corrosion on joint surfaces
  4. Those not including silicon type



## 4-5. Installation procedure

### <Attaching External Cable>

The detector comes with adapter A (NPT 1/2) as standard.  
Please prepare the Ex cable gland that is suitable for the adapter.

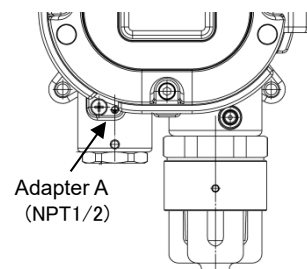

### WARNING

- Do not replace parts at your sole discretion but contact RIKEN KEIKI if the transparent window has a crack or the explosion-proof joint surface is abnormal, or the clamping screw or bolt is changed, lost etc.

### NOTE

- Our company-specified grease : BARRIERTA JFE 552 (manufactured by NOK KLUBER)  
If you can not prepare the specified grease, use one that meets the following requirements.
  1. Material does not harden due to deterioration
  2. Volatile solvent-free
  3. Material does not cause corrosion at the surface
  4. Silicon-free
  5. Validation of suitability depends on the specifications of grease manufacturer

## 4-6. How to wire



### CAUTION

- Be careful not to damage the internal electronic circuit when wiring. In addition, be careful not to apply stresses on the detector when (overweight) cables are installed.
- The power cables and signal cables must not be installed together with the motor power cables etc. When these cables must be installed together for unavoidable reasons, put the power cables and signal cables in a metal conduit. The conduit must be connected to a grounding circuit.
- When stranded wires are used, prevent wires from contacting each other.
- Use the dedicated handling lever to wire.
- Use appropriate cables to wire.

### <Recommended Cable>

3-wire	CVVS1.25 mm <sup>2</sup> or 2.0mm <sup>2</sup> - 3-core
4-wire	CVVS1.25 mm <sup>2</sup> or 2.0mm <sup>2</sup> - 4-core

### <Figure of Terminal Plate>

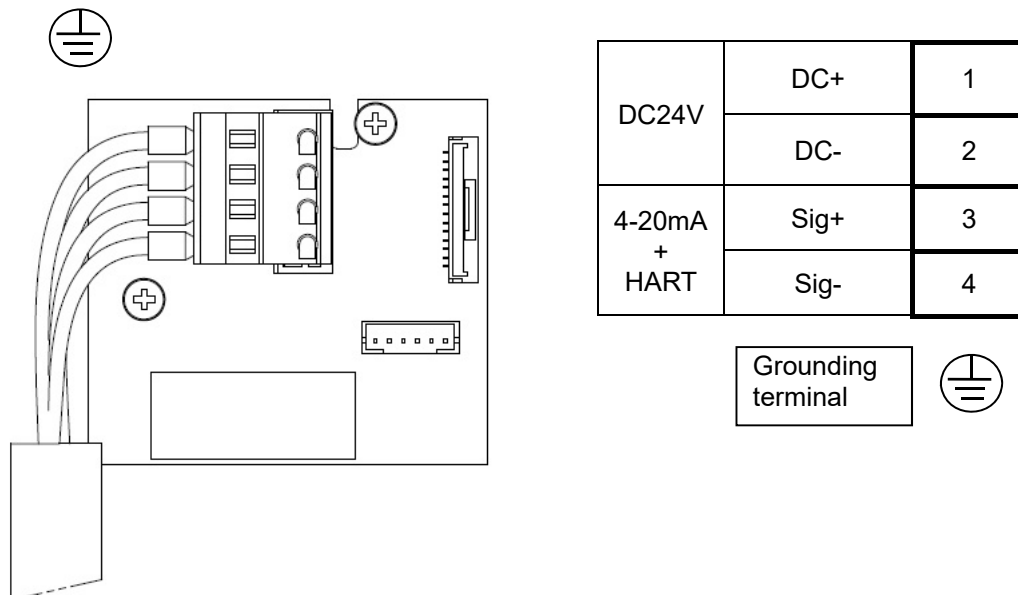

### <Specifications of Terminal Plate>

#### Specifications of terminal plate

Rated voltage: 250 VAC

Rated current: 12 A

However, it depends on cables to be used.

#### Connection conditions

Cables: 0.25 - 2.5 mm<sup>2</sup>

Bare wire length: 8 - 9 mm

Connecting tool: Dedicated handling lever (accessory) or driver (edge 3.5 x 0.5 mm)

## &lt;When 4-20mA output is not used&gt;

This detector has a self-diagnosis function which shows E-9 on LED display when 4-20mA is not properly outputted.

If 4-20mA output is not necessary, connect the following fixed resistance (lead type) to the terminal 2 and 3 ("Sig+" and "-(common)").

Resistance value : 100-300Ω Rated power : 0.25W or more

Insert a cable and the above resistance together into Terminal 2 (common), and insert lead part of the resistance into terminal 3 (Sig+). After that, check the immovability.

**CAUTION**

The specified bare wire length must be observed when the wire insulation is peeled off.

Improper clamping of the wire due to a shorter bare wire length may cause defective electrification or heating.

Damaging the wire insulation due to a shorter bare wire length may cause defective electrification or heating.

Exposing the wire due to a longer bare wire length may cause defective insulation or a short circuit.

Be careful not to break up the wire. If the wire is broken up when inserted to the terminal, this may cause defective insulation or heating.

Compatible bar terminal

For a bar terminal, the following items are available.

Bar terminal (ferrule): Model 216 Series (manufactured by WAGO)

Crimping tool: Model VarioCrimp 4 (206-204) (manufactured by WAGO)

**CAUTION**

A bar terminal of the specified model must be used. Using other bar terminals invalidates the warranty of the performance.

## &lt;How to Connect to Terminal Plate&gt;

When cables are connected to the connectors, use the dedicated lever or a flathead screwdriver to do it as shown below.

**CAUTION**

The right tools must be used.

In principal, one wire can be connected to one wiring hole.

When the wire is inserted into the driver slot by mistake, it does not contact the conductive part. This may cause defective electrification or heating.

When the wire is inserted under the spring by mistake, it does not contact the conductive part. This may cause defective electrification or heating.

**NOTE**

<How to Use the Dedicated Handling Lever>

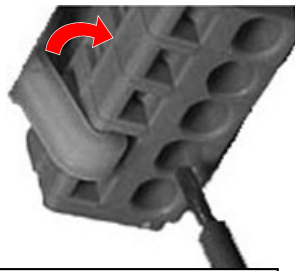

Push the lever with your finger to lower the spring in its inside.

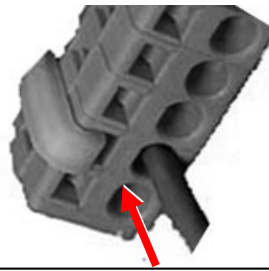

While holding down the lever, insert the wire into the (round) wiring hole until it reaches the deepest point. Once the lever is released, the wire is secured.

To check whether the wire is connected securely, pull the wire gently. (Do not pull the wire strongly.)

<Grounding>

Connect the detector to your grounding terminal with the external terminal .



**WARNING**

- Before turning on the detector, do not forget to connect it to a grounding terminal.
- For stable operation of the detector and safety, it must be connected to a grounding terminal. Do not connect the grounding wire to a gas pipe.
- The grounding must be made as D type grounding (below 100 Ω of grounding resistance).
- For the grounding wire, use cable lugs to safely connect it to a grounding terminal without looseness or twist.
- To connect the grounding wire to the internal grounding terminal of the main unit, use crimp terminal, and use external grounding wire with a cross sectional area of 4 mm<sup>2</sup> or more for the external grounding terminal.

<Wiring Example>

Connecting to the indicator

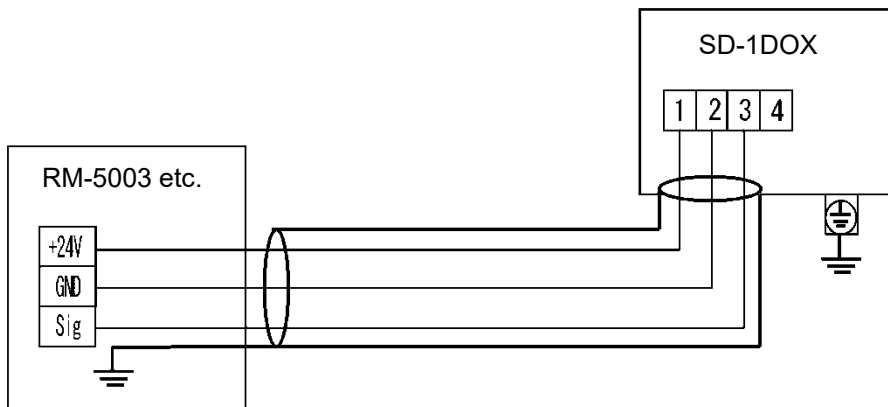

Connecting to the upper unit (DCS, PLC)

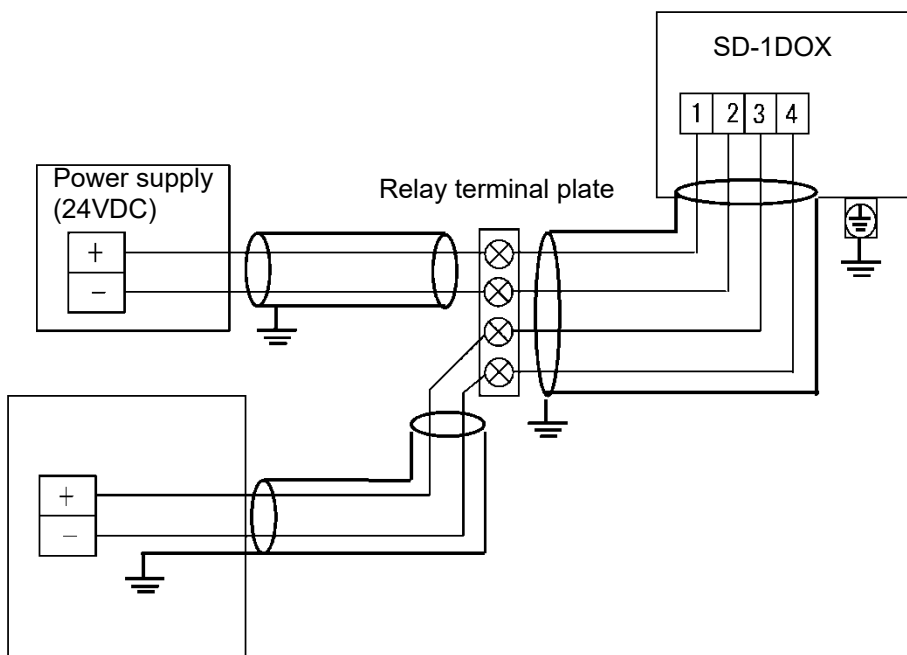

**CAUTION**

If HART communication is used, check so that wiring load resistance that constitute 4-20mA loops, amount to 250 Ω-300 Ω.

## 4-7. How to tube

The detector has a Rc1/8 thread inside of the sampling inlet/outlet (GAS IN, GAS OUT), the "PP" unions is normally attached. Because their material varies depending on the gas to be used, please specify the appropriate unions.

The compatible tube is a tube of  $\Phi 6$  (OD) -  $\Phi 4$  (ID). The tube must be installed with the supplied inners and sleeves attached to prevent a leak.

When the tube is cut, its cut point has a smaller inner diameter. Use a file etc. to expand the inner diameter of the cut point. To remove cut-dust remaining inside of the tube, blow compressed air into the tube before connecting it to the detector.

Some sample gases have highly adsorptive or corrosive property. Select the tube material taking into account of these precautions.

Be careful that the flow rate introduced to the detector is in the range of 0.8 - 2 L/min (the maximum pressure inside the flow path and sensor parts is 10.13 kPa <gauge pressure>).



### WARNING

- The detector is designed to draw gases around it under the atmospheric pressure. Be sure that excessive pressure is not applied to the sampling inlet and outlet (GAS IN, GAS OUT) of the detector.
- Detected gases must be exhausted from the detected gas exhausting outlet (GAS OUT) to which an exhaust tube is connected, to a point regarded as a safe place.



### CAUTION

- The longer the tube of the GAS IN is, the longer it takes for a gas to reach the detector. Because some gases have a highly adsorptive property for the tube, resulting in a slow response and a lower reading than the actual value, the length of the GAS IN tube must be minimized.
- When the humidity in the sampling point is high, condensation may be formed inside of the tube. Make sure to avoid condensation when using a gas which is dissolved into water and corrodes contacted materials, such as a strong acid gas, because it is undetectable and furthermore may corrode internal parts. Also avoid an excessive U-shaped or V-shaped tube piping.
- Determine the inlet for the sample gas, considering the air flow of the sample gas line and the gas generating process.
- To remove dust, do not forget to attach a dust filter in the middle of the tube.
- You need to decide the length and material of the tube. Please contact RIKEN KEIKI for more information.

# 5

# How to Operate

## 5-1. Preparation for start-up

Before connecting a power supply, read and understand the following precautions. Ignoring these precautions may cause an electric shock or damage the detector.

- Connect the detector to a grounding circuit.
- Check that the wiring is connected to external device properly.
- Check that the power supply voltage is compliant with the specifications.

## 5-2. Basic operating procedures

Normally, the detection mode is used for normal operations. (The detection mode is activated after the power is turned on.)

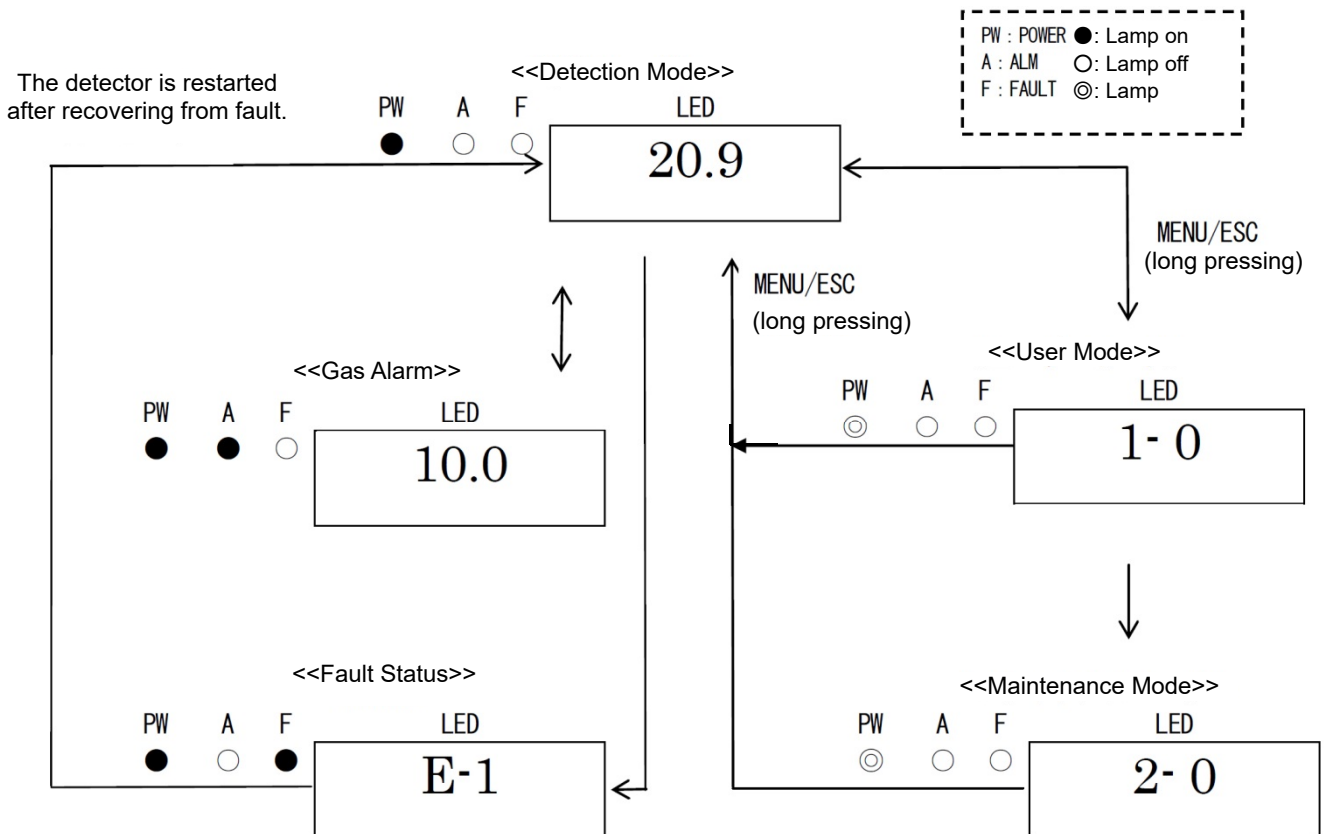

### WARNING

When the detector enters other mode from the detection mode while an alarm is activated, the alarm is reset.

### 5-3. How to start the gas detector

- Before supplying power (24 VDC) to the detector, check that the detector is installed properly.
- Supply power (24 VDC) to the detector (turn on the detector).
- After the detector completes the start-up, it enters the detection mode swiftly.
- Be careful that the flow rate introduced to the detector is in the range of 0.8 - 2 L/min (the maximum pressure inside the flow path and sensor parts is 10.13 kPa <gauge pressure>).



#### CAUTION

- Do not turn off the detector during the initial clear. The detector is reading the internal memory during the initial clear.
- After initialization is complete, perform a span adjustment.

#### NOTE

<<Start-up Operation Procedures>> (approximately 25 seconds for system check of the detector and alarm deactivation)

Power on -> Initial clear (approximately 25 seconds) -> Detection mode

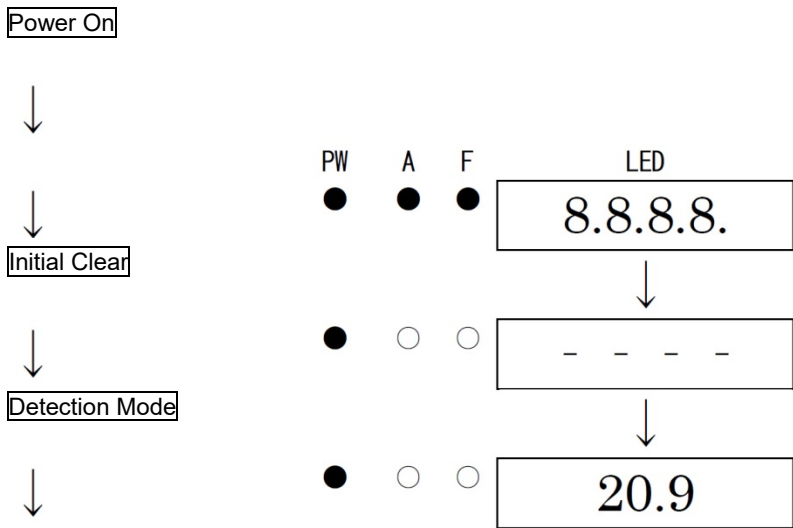



## 5-4. Modes

Details on each mode are provided as follows.



### CAUTION

- Do not change the settings if not necessary. Changing the settings without understanding the specifications may cause malfunctions.

Mode	Item	LED display	Details
Detection Mode	-	Gas concentration	Normal state
Maintenance Mode (User)	ROM/SUM Display	1-0	Display the program version and others. This is not typically used by the user.
	Span Adjustment (AIR adjustment)	1-1	Perform the span adjustment (AIR adjustment).
	Setting Display	1-2	Display various setting values.
	Switch to Maintenance Mode	1-3	Switch to the regular maintenance mode.
Maintenance Mode (Regular maintenance)	Test Mode	2-0	Perform various tests. 2-0.0 Gas Test 2-0.1 Alarm Test 2-0.2 Fault Test 2-0.3 LED Test 2-0.4 Memory Test
	Zero Adjustment (N2 adjustment)	2-1	Perform the zero adjustment (N2 adjustment).
	Span Adjustment (AIR adjustment)	2-2	Perform the span adjustment (AIR adjustment).
	Zero/Span Initialization	2-3	Initialize zero/span values.
	Environmental Setting	2-4	Used for various environmental settings. 2-4.0 Sensor Power Supply ON/OFF 2-4.1 INHIBIT Setting 2-4.2 Alarm Setpoint Setting 2-4.3 Alarm Delay Time Setting 2-4.4 Alarm Pattern Setting 2-4.5 Suppression Type Setting 2-4.6 Suppression Value Setting for 20.9% 2-4.7 Not used. 2-4.8 Not used. 2-4.9 Not used. 2-4.A Maintenance Mode External Output Setting 2-4.B External Output Adjustment 2-4.C Alarm Test External Output Setting 2-4.D Not used. 2-4.E Password Setting 2-4.F Sensor Fault Alarm Pattern Setting
	Display	2-5	Display various electrical settings. This is not typically used by the user.
	Switch to Factory Mode	2-6	Not used.
	Switch to User Mode	2-7	Returns to the user mode.

※Maintenance mode has setting item with important tool. As operation that mistook for this reason may be occurred, this detector to malfunction, our service engineer for maintenance manipulate. This is not typically used by the user.

## 5-5. Maintenance mode(User)



### WARNING

After the adjustment is completed, never fail to press MENU/ESC key to return to the detection mode.  
 (If the detector remains in the user mode, it automatically returns to the detection mode in ten hours.)

**Detection Mode**

Press the MENU/ESC key for three seconds.

PW	A	F	LED	
<input checked="" type="radio"/>	<input type="radio"/>	<input type="radio"/>		20.9



**User Mode**

**1-0. ROM/SUM Display**

Display the program version and others. This is not typically used by the user.

PW	A	F	
<input checked="" type="radio"/>	<input type="radio"/>	<input type="radio"/>	1- 0



**1-1. Span Adjustment**

Perform the span adjustment.

PW	A	F	▲ ↓ ↑ ▼ LED	
<input checked="" type="radio"/>	<input type="radio"/>	<input type="radio"/>		1- 1

→ Span Adjustment => P25  
SET

**1-2. Various Setting Display**

Display various setting values.

PW	A	F	▲ ↓ ↑ ▼ LED	
<input checked="" type="radio"/>	<input type="radio"/>	<input type="radio"/>		1- 2

→ Setting Display => P26  
SET

**1-3. Mode Switching**

Switch to the regular maintenance mode.  
 This is not typically used by the user.

PW	A	F	▲ ↓ ↑ ▼ LED	
<input checked="" type="radio"/>	<input type="radio"/>	<input type="radio"/>		1- 3



<Span Adjustment (AIR adjustment)"1-1">

This is used to perform the zero adjustment (AIR adjustment).

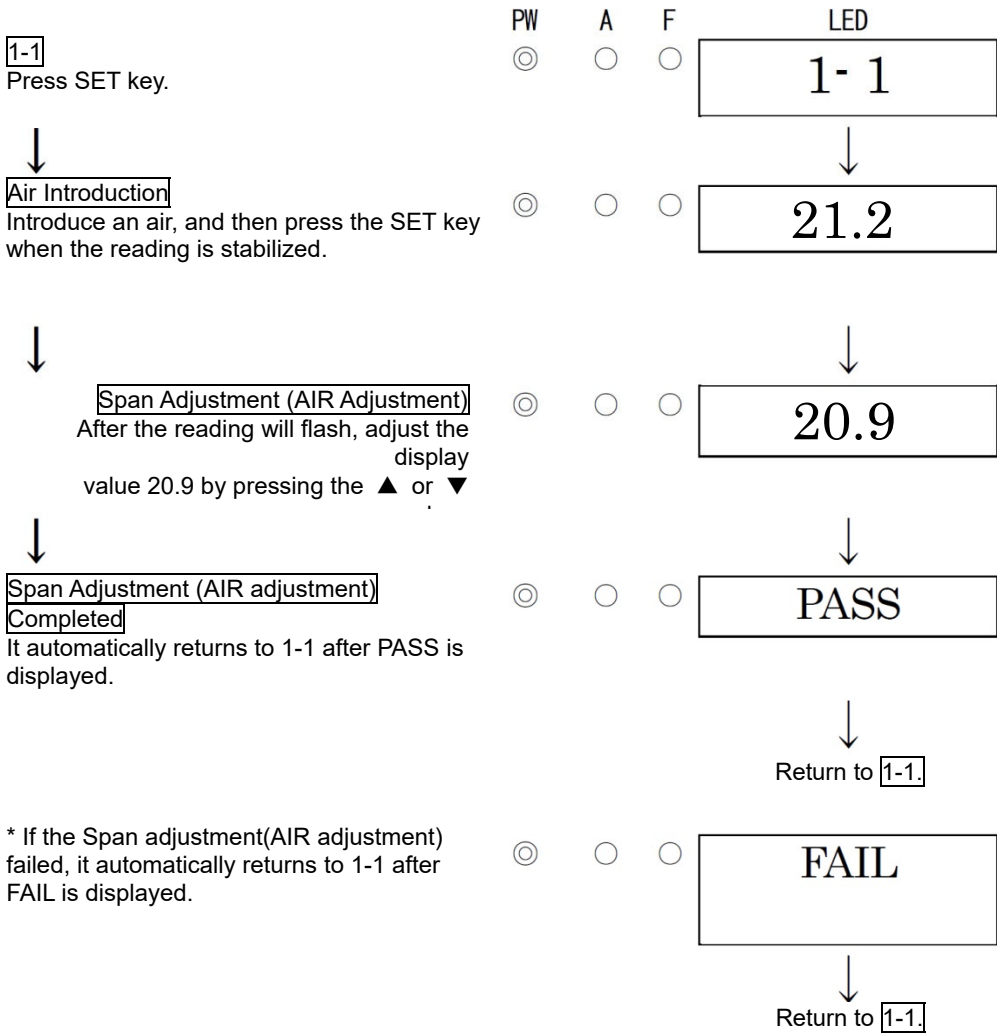

\* If the Span adjustment(AIR adjustment) failed, it automatically returns to 1-1 after FAIL is displayed.

**NOTE**

- If the span adjustment (AIR adjustment) failed since the span point was significantly fluctuated from around 20.9%, it returns to 1-1 after FAIL rather than PASS is displayed. In this case, the span adjustment (AIR adjustment) has not been completed.

<Setting Display "1-2">  
 Display various setting values.

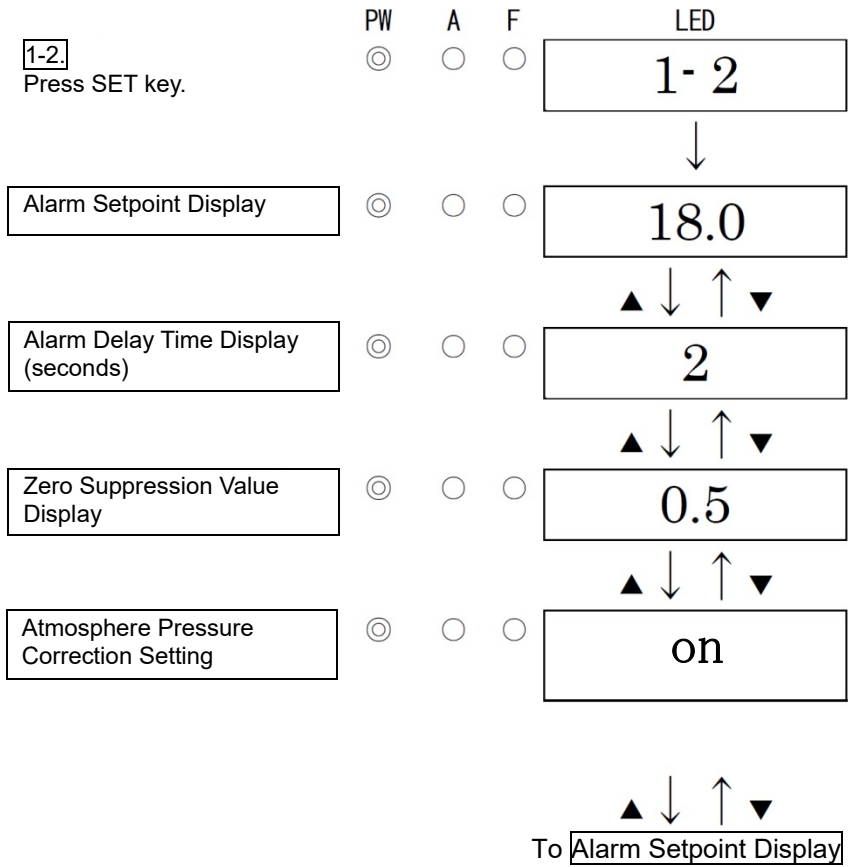

## 5-6. How to exit

To turn off the detector, turn off the power supply (24 VDC) to the detector.



### WARNING

- When the detector is turned off, an alarm may be triggered on the upper (central) system.
- Before turning off the detector, INHIBIT (point skip) on the upper (central) system must be activated. Decide whether the power can be turned off by checking the operation of the devices connected to the external output or external contact output terminal of the detector.

## 6

# Operations and Functions

## 6-1. Alarm activation

Oxygen concentration alarm: Activated when the detected oxygen concentration reaches or exceeds the alarm setpoint value. <<Auto-Reset Operation>>

### NOTE

The alarm setpoint is factory-set. Although the alarm delay time (standard: 2 seconds) works in the detector to prevent a false activation, it can be cancelled if not needed.

### <Display Operation>

#### Oxygen Concentration Display

In case of over the detection range (Over Scale), "∞ ∞ ∞ ∞" is displayed on the LED.

#### Power Indicator Lamp (POWER: Green)

During operation, this lights up continuously.

#### Alarm Indicator Lamp (ALM: Red)

This lights up when the alarm setpoint value is reached or fell below.

### <Alarm Activation>

The lamp illuminates solid when the oxygen concentration reaches or falls below the alarm setpoint value (only when the alarm is used).

The alarm activation maintains the alarm state even when the gas concentration exceeds the alarm setpoint value.

Verify that the environment is no longer in the alarm condition and manually operate the keys. The latched alarm can be cancelled with manual key operation.

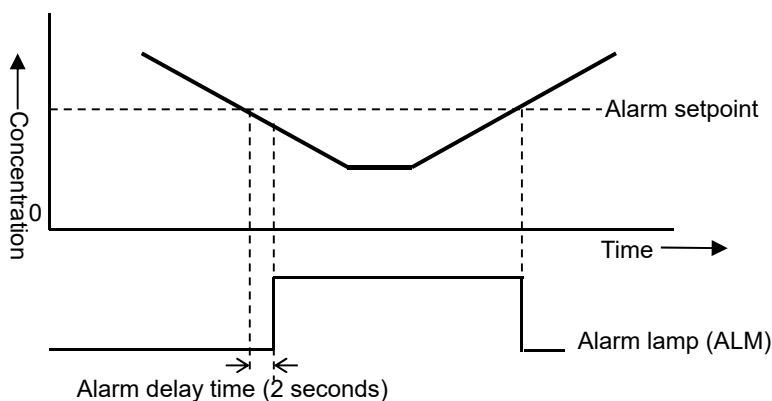

### <Response to Alarm>

An oxygen concentration value falls below the alarm setpoint

When an alarm is triggered, take actions in accordance with your management rules of alarm. Normally, take the following actions.

- Check the reading of the detector.

### NOTE

If a gas leak is temporary, the reading may already have returned to normal by the time of inspection when checking it. In addition, when the alarm is triggered by noise or other incidental conditions other than a gas, the reading may have already returned to normal.

- Based on your management rules of gas alarm, no one can be allowed to access the monitored zone to ensure safety.
- If the gas concentration display continues to be displayed, close the main valve of the gas, and then check that the gas concentration reading rose.
- Access the gas leak point, equipped with a protective gear to avoid dangers caused by possibly remaining gases, and check whether gases remain or not by using a portable gas detector.
- Check that the point is free from dangers, and take actions to fix the gas leak.

## 6-2. Fault alarm activation

A fault alarm is triggered when the detector detects abnormalities. After a fault alarm is triggered, the fault lamp (yellow) lights up and an error message is displayed on the LCD. Determine the causes and take appropriate actions.

After the detector is successfully returned from the fault, it restarts with the process normally performed right after it is turned on (initial clear).

If the detector has problems and is repeatedly malfunctioning, contact our overseas sales department or local representatives immediately.

### <Display Operation>

Fault Detail Display

Display a message indicating the fault detail.

Fault Lamp (FAULT: Yellow)

This lights up when a failure occurs.

### NOTE

For information on malfunctions (error messages), see "9. Troubleshooting".

## 6-3. Warning activation

When the environmental temperature exceeds the operating temperature of the detector, gas concentration and warning number[E-27] are shown alternately. Since this case is not failure, still the detector works. It outputs 4-20mA depending on gas concentration and does not light up failure lamp.

Operating temperature: -10~+40°C(non-rapidly-vary)

## 6-4. External output operation

Signal Transmission System		Electric current transmission (non-isolated) 4 – 20 mA
Transmission Path		CVVS
Transmission Distance		CVVS 1.25 mm <sup>2</sup> : Within 1.25km CVVS 2.0 mm <sup>2</sup> : Within 2.0km
Connection Load Resistance		Below 300 Ω
	Mode	4 - 20 mA(output value)
1	Power Off	0 mA
2	Initial Clear	21.5 mA (Fixed)
3	Detection Mode(No alarm)	4 - 20 mA (concentration output)
4	Detection Mode(Gas alarm)	4 - 20 mA (concentration output)
5	Detection Mode (Full scale over)	20.5 mA (Fixed)
6	Out of operating temperature range	4 - 20 mA (concentration output)
7	Fault Alarm	0.5 mA (Fixed)
8	INHIBIT	21.5 mA (Fixed)
9	Alarm Test Mode	Output ON setting: 4 - 20 mA (concentration output) Output OFF setting: 4 mA
10	User Mode	4 - 20 mA (concentration output)
11	Maintenance Mode	21.5 mA (Fixed)

Example of Gas Concentration and External Output  
0 - 25 vol% (Oxygen deficiency alarm specification)

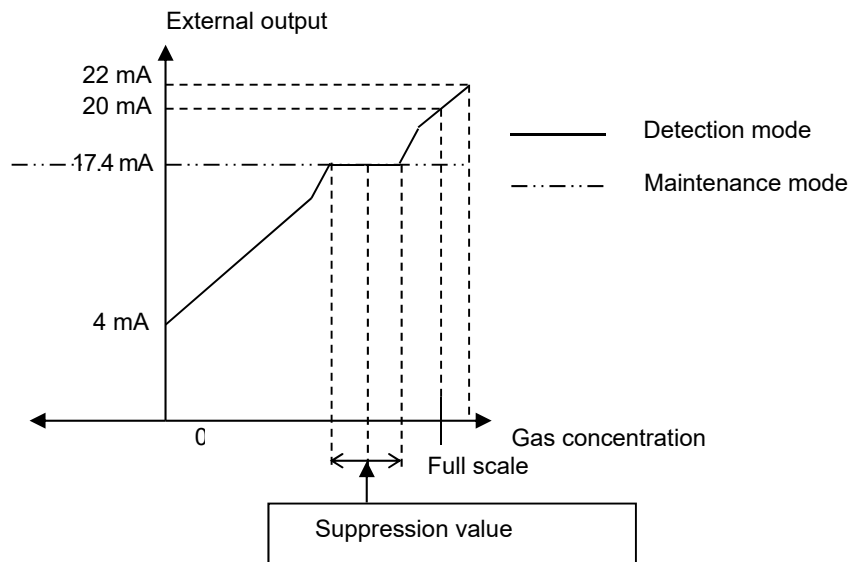

### CAUTION

- The 4 - 20 mA output is already adjusted. In case of over scale, an output will not exceed 20.5 mA.
- Output during INHIBIT or initial clear is based on 4 - 20 mA output setting in the maintenance mode.

In particular, when the detector is started or the specification is changed, be careful about 4-20 mA output setting. Understand how the detector functions, and take actions, if necessary, so that the signal receiver side can prepare to avoid false alarms.

## 6-5. Other functions

### <Suppression Function>

The sensors used with the detector are influenced by environmental changes (temperature, humidity and other characteristics) in no small measure, which affects the reading. Therefore, the reading might be fluctuated even in a normal environment.

This function obscures influences by environmental changes or other factors that have no meaning for your management rules of alarm. This function is used to hide (suppress) the fluctuation of the reading under the setting value, indicating 20.9 vol%.

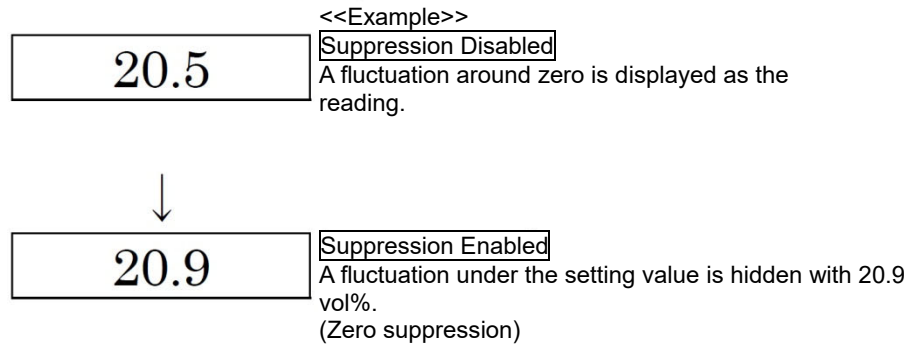

#### NOTE

- The suppression function is factory-set. The standard setting value is  $\pm 0.5$  vol% (for 20.9 vol%).
- In the maintenance mode, this function is disabled and the fluctuation of the reading under the setting value is displayed.



#### CAUTION

A reading under zero is suppressed with the 10% FS suppression.  
A reading that is 10% FS or more under zero is displayed as "-0.0", which prevents an accurate gas detection and needs the zero adjustment.



---

# 7

---

## Maintenance

The gas detector is an important instrument for the purpose of safety. To maintain the performance of the gas detector and improve the reliability of safety, perform a regular maintenance.

### 7-1. Maintenance intervals and items

- Daily maintenance: Perform maintenance before beginning to work.
- Monthly maintenance: Perform maintenance on the alarm circuit (alarm test) once a month.
- Regular maintenance: Perform maintenance once or more for every six months to maintain the performance as a safety unit.

Maintenance item	Maintenance content	Daily maintenance	Monthly maintenance	Regular maintenance
Power Supply Check	Check that the power lamp lights up.	○	○	○
Concentration Display Check	Check that the concentration display value is zero. When the reading is incorrect, perform the zero adjustment after ensuring that no interference gases exist around it.	○	○	○
Flow rate check	Check the flow rate to find abnormalities.	○	○	○
Filter check	Check the dust filter for dust or clogging.	○	○	○
Alarm Test	Inspect the alarm circuit by using the alarm test function.	—	○	○
Span Adjustment	Perform the span adjustment by using the calibration gas.	—	—	○
Gas Alarm Check	Check the gas alarm by using the calibration gas.	—	—	○
Ground wire check	Check the connection of the grounding wire (no looseness or corrosion) to maintain EMC performance.	—	—	○

#### <About Maintenance Services>

- We provide services on regular maintenance including span adjustment, other adjustments and maintenance.  
To make the calibration gas, dedicated tools, such as a gas cylinder of the specified concentration and gas sampling bag must be used.  
Our qualified service engineers have expertise and knowledge on the dedicated tools used for services, along with other products. To maintain the safety operation of the detector, please use our maintenance service.
- The followings are typical maintenance services. For more information, please contact RIKEN KEIKI.

Main Services

Power Supply Check	: Checks the power supply voltage. Verifies that the power lamp lights up. (Verifies that relevant points can be identified on the system.) (When a UPS (uninterruptible power system) is used, checks the operation with the UPS.)
Concentration Display Check	: Verifies that the concentration display value is zero (or 20.9 vol% on the oxygen deficiency meter) by using the zero gas. Performs the zero adjustment (fresh air adjustment) if the reading is incorrect.
Flow Rate Check	: Checks the flow rate indicator to find abnormalities. Checks the flow rate by using an external flow meter to verify the correctness of the flow rate indicator on the gas detector. If the flow rate is incorrect, performs the flow rate adjustment.
Filter Check	: Checks the dust filter for dust or clogging. Replaces a dirty or clogged dust filter.
Alarm Test	: Inspects the alarm circuit by using the alarm test function. <ul style="list-style-type: none"> <li>• Checks the alarm lamps. (Checks ALM activation.)</li> <li>• Checks the external alarm. (Checks the activation of the external alarm, such as a buzzer.)</li> </ul>
Span Adjustment	: Performs the span adjustment by using the calibration gas.
Gas Alarm Check	: Checks the gas alarm by using the calibration gas. <ul style="list-style-type: none"> <li>• Checks the alarm. (Checks triggering of alarm when the alarm setpoint is reached.)</li> <li>• Checks the delay time. (Checks time to delay until the alarm is triggered.)</li> <li>• Checks the alarm lamps. (Checks ALM activation.)</li> <li>• Checks the external alarm. (Checks the activation of external alarms, such as a buzzer and reset signal.)</li> </ul>
Cleaning and Repair of Device (Visual Diagnosis)	: Checks dust or damage on surface, cover or internal parts of the detector, cleans and repairs such parts of the detector. Replaces parts which are cracked or damaged.
Device Operation Check	: Uses the keys to check the operation of functions and parameters.
Replacement of Consumable Parts	: Replaces consumable parts, such as a sensor, filter and pump.

## 7-2. Maintenance mode(Regular maintenance)



### WARNING

After the adjustment is completed, never fail to press MENU/ESC key to return to the detection mode.  
 (If the detector remains in the regular maintenance mode, it automatically returns to the detection mode in ten hours.)

Mode	Item	LED display	Details
Maintenance Mode (Regular maintenance)	Test Mode	2-0	Perform various tests. 2-0.0 Gas Test 2-0.1 Alarm Test 2-0.2 Fault Test 2-0.3 LED Test 2-0.4 Memory Test
	Zero Adjustment (N2 adjustment)	2-1	Perform the zero adjustment (N2 adjustment).
	Span Adjustment (AIR adjustment)	2-2	Perform the span adjustment (AIR adjustment).
	Zero/Span Initialization	2-3	Initialize zero/span values.
	Environmental Setting	2-4	Used for various environmental settings. 2-4.0 Sensor Power Supply ON/OFF 2-4.1 INHIBIT Setting 2-4.2 Alarm Setpoint Setting 2-4.3 Alarm Delay Time Setting 2-4.4 Alarm Pattern Setting 2-4.5 Suppression Type Setting 2-4.6 Suppression Value Setting for 20.9% 2-4.7 Not used. 2-4.8 Not used. 2-4.9 Not used. 2-4.A Maintenance Mode External Output Setting 2-4.B External Output Adjustment 2-4.C Alarm Test External Output Setting 2-4.D Not used. 2-4.E Password Setting 2-4.F Sensor Fault Alarm Pattern Setting
	Display	2-5	Display various electrical settings. This is not typically used by the user.
	Switch to Factory Mode	2-6	Not used.
	Switch to User Mode	2-7	Returns to the user mode.

### < Environment setting items and adjustment range >

The unit is set at the factory to operate properly. Changing settings is not recommended. If any change is necessary, carefully consider that there are no operational problems.

LED display	Item	Factory setting value	Adjustable range
2-4.1	INHIBIT	OFF	OFF / ON
2-4.2	Alarm Setpoint	18.0vol%	10% FS to 100% FS
2-4.6	Zero Suppression Value	0.5vol%	20.4vol% to 21.4vol%

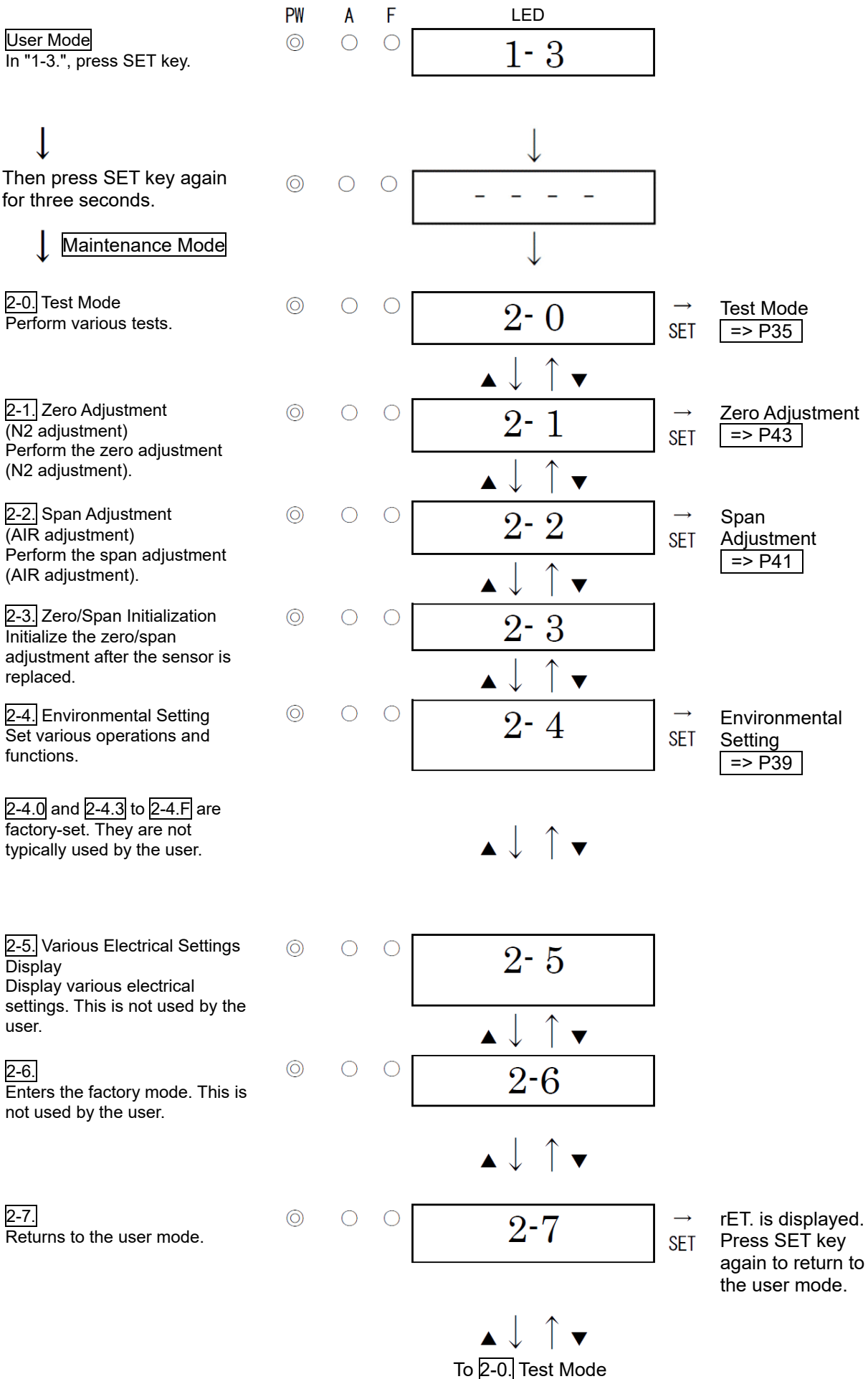

<Test Mode "2-0">

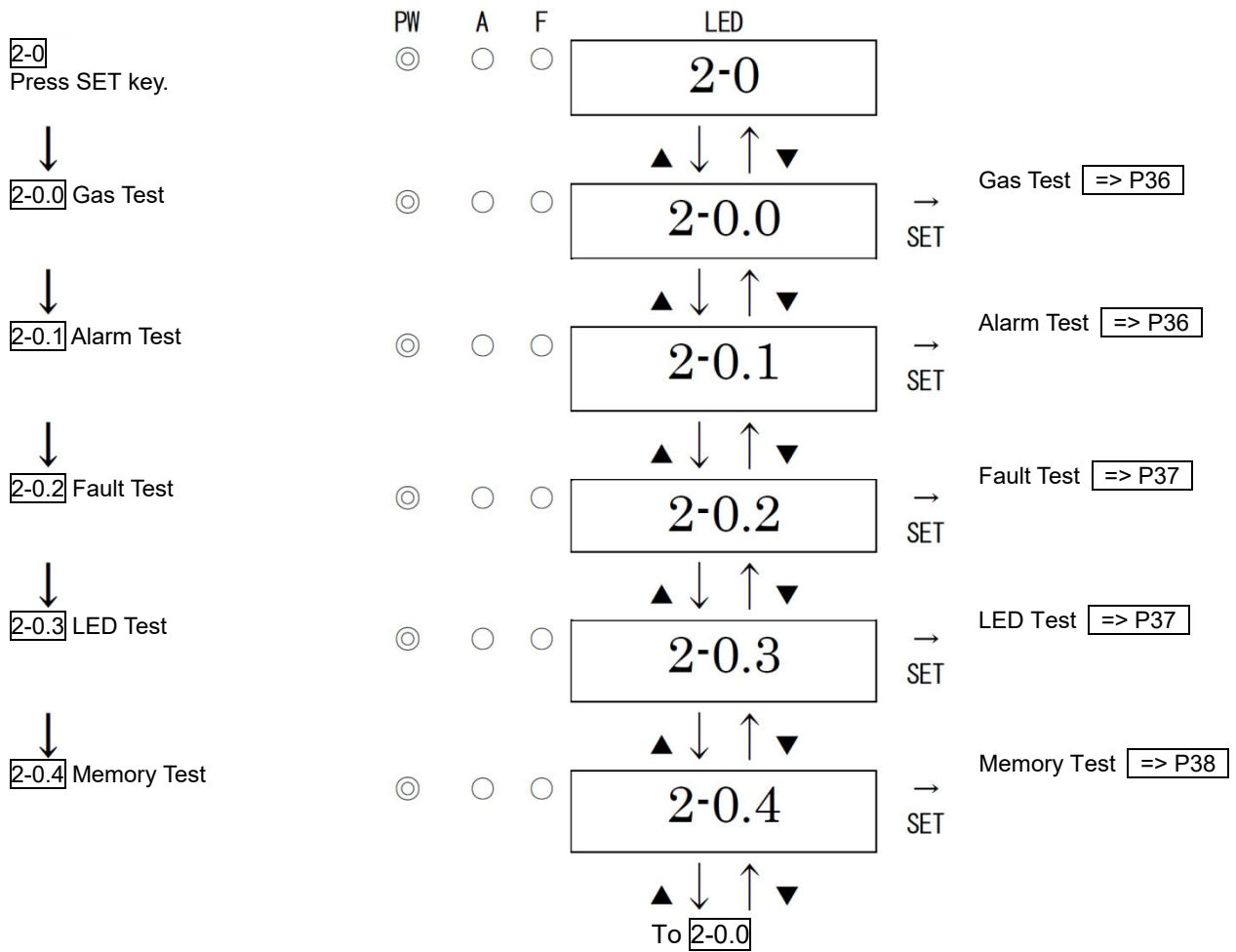

**WARNING**

- Before starting the alarm test (transmission test), provide a notification to the related sections so that they can prepare for false abnormalities (external output signals and alarm contact). After the test is completed, never fail to press MENU/ESC key to return to the detection mode. (If the detector remains in the alarm test mode, it automatically returns to the detection mode in ten hours.)
- In the alarm test mode, the gas concentration equal to the reading is output even in the maintenance mode depending on the setting. Take actions, if necessary, so that the signal receiver side can prepare to avoid false alarms.

<Gas Test "2-0.0">

2-0.0

Press SET key.



Introduce the test gas and perform the gas test.

Stop introducing the test gas. When the reading increases, press the MENU/ESC key to cancel the test and to go back to the original state.

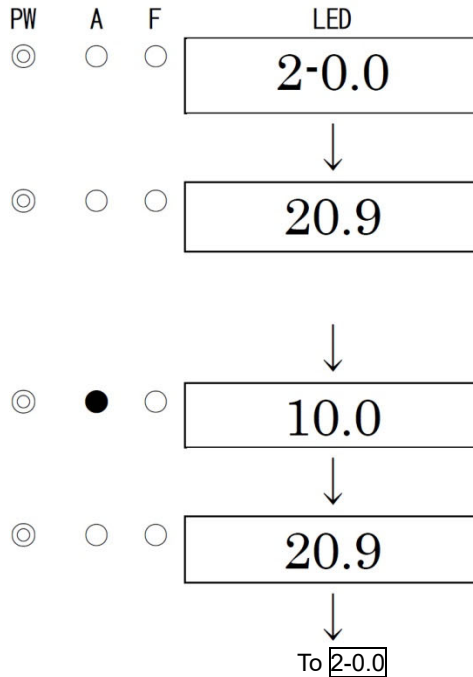

**WARNING**

Be careful to perform the test because the contact and gas concentration output can be activated by a gas test even in the maintenance mode depending on setting.

<Alarm Test "2-0.1">

2-0.1

Press SET key.



Alarm Test ON/OFF

(The contact setting is "Alarm" or "Alarm or Fault")

Select either ON/OFF, and then press the SET key.

Perform the gas alarm test by increasing or decreasing the reading with the ▲ or ▼ key. Press the MENU/ESC key to cancel the test and to go back to the original state.

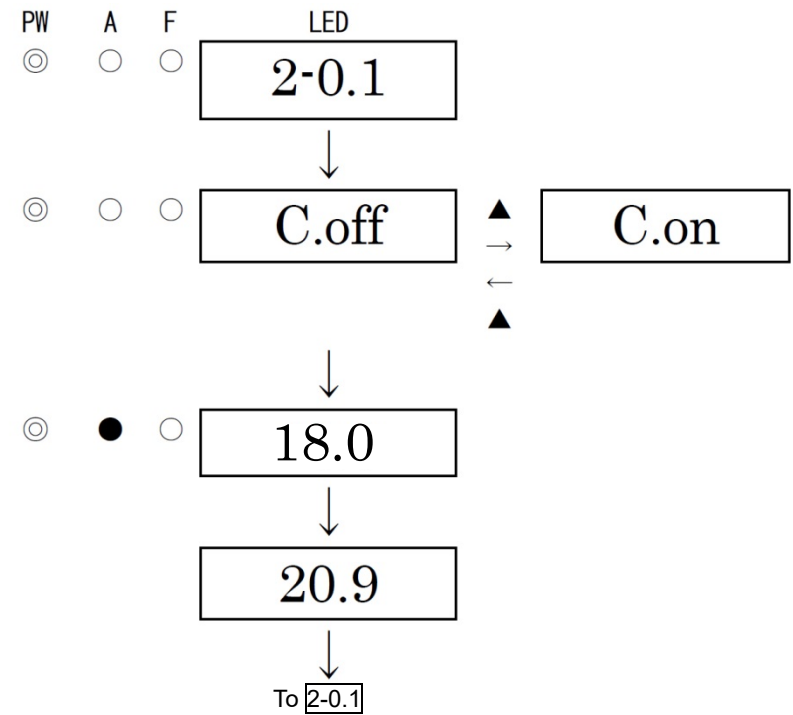

**WARNING**

Be careful to perform the test because the contact and gas concentration output can be activated by an alarm test even in the maintenance mode depending on setting.

<Fault Test "2-0.2">

**2-0.2**

Press SET key.



**Fault Test ON/OFF**

Select either ON/OFF.

Switch ON and press the SET key to trigger the fault alarm.

Return to OFF and press the SET key to cancel the test.

(Pressing the MENU/ESC key also enables to cancel the test and to go back to the original state.)

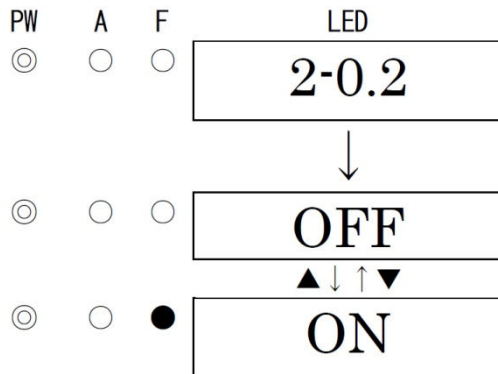

**WARNING**

Be careful to perform the test because the contact and gas concentration output can be activated by a fault test even in the maintenance mode depending on setting.

<LED Test "2-0.3">

**2-0.3**

Press SET key.



**LED Test ON/OFF**

Select either ON/OFF.

Switch ON and press the SET key to turn on the LEDs (POWER, ALM, FAULT) and to display the gas concentration of 8.8.8.8.

Return to OFF and press the SET key to cancel the test.

(Pressing the MENU/ESC key also enables to cancel the test and to go back to the original state.)

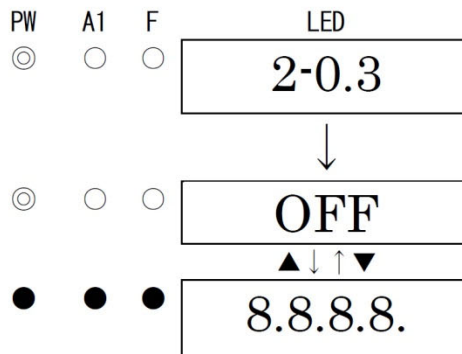

## &lt;Memory Test "2-0.4"&gt;

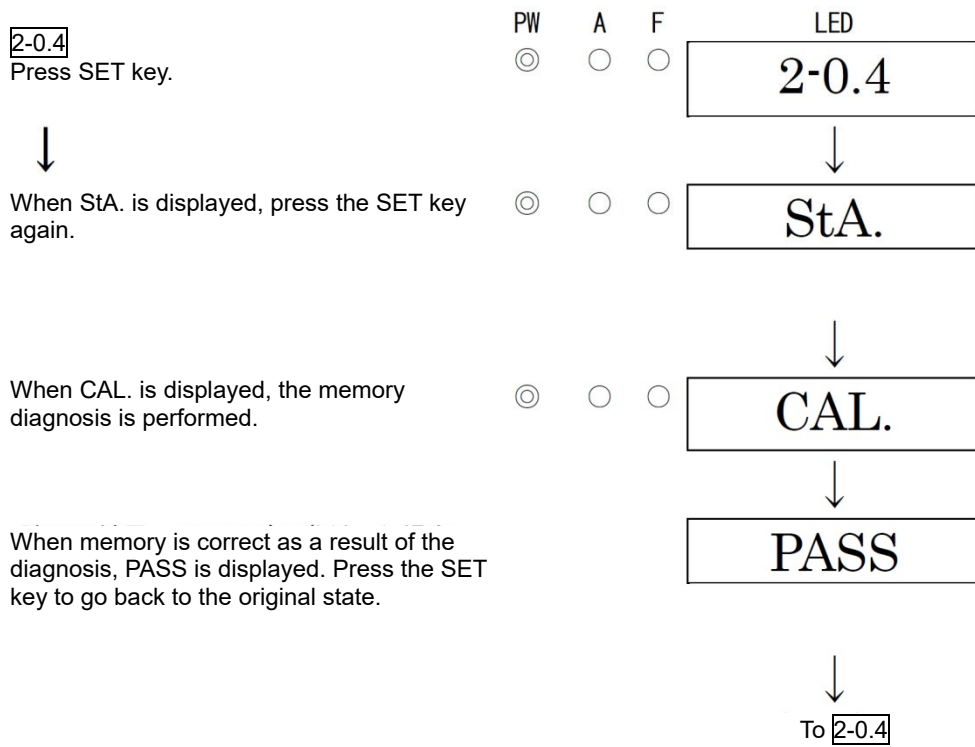
**NOTE**

When abnormalities are found in memory as a result of the diagnosis, PASS is not displayed. F-RA is displayed for the RAM fault, and F-RO is displayed for the ROM fault. For both the RAM fault and ROM fault, F-RA and F-RO are displayed alternately.



### <Environmental Setting "2-4">

Set various operations and functions in the environmental setting.

<<Environmental Setting 1>>  
 2-4. Environmental Setting  
 Press SET key.

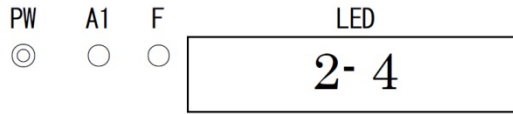

2-4.0  
 They are factory-set and not typically used by the user.

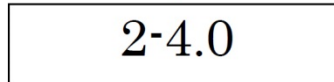

2-4.1 INHIBIT Setting  
 Set Inhibit.  
 Select either ON/OFF, and then press the SET key to confirm the selection.  
 When ON is selected, in the detection mode [nHI.] and [0.0] (gas concentration value) are displayed on the LED alternately.  
 As a result, an alarm is not triggered to external device.

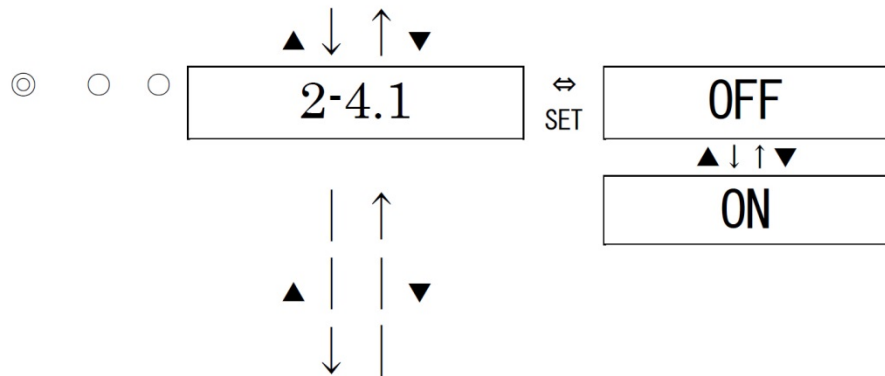

2-4.2 Alarm Setpoint Setting  
 Set the alarm setpoint.



2-4.3 to 2-4.F  
 They are factory-set and not typically used by the user.

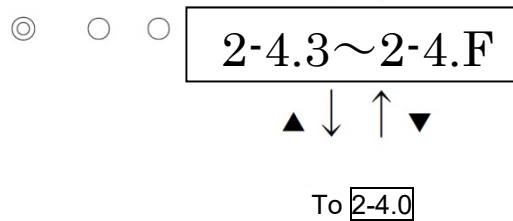

### <Alarm Setpoint Setting "2-4.2">

2-4.2  
 Press SET key.

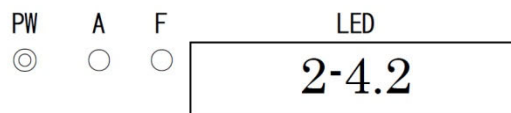

Alarm Setpoint Setting  
 Change the value by pressing the ▲ or ▼ key, and then press the SET key to confirm the value.  
 (Press the MENU/ESC key to go back to the original state.)

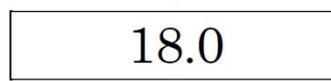

Return to 2-4.2

## <Suppression Value Setting for 20.9% "2-4.6", Negative Suppression Value Setting "2.4.J">

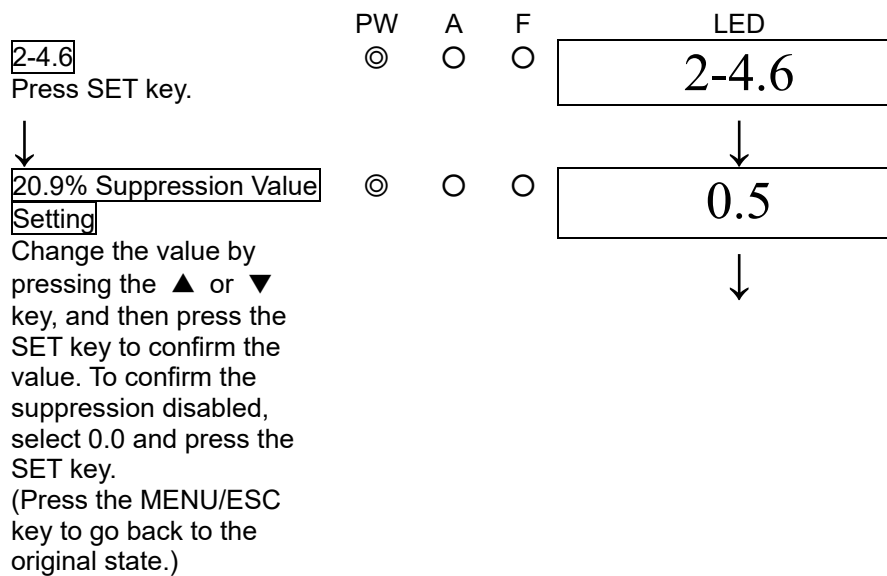

Return to 2-4.6

※"2.4.J" can be set in a similar way.

## 7-3. Calibration method

Perform a calibration in each mode (zero adjustment mode and span adjustment mode) using the calibration gas.

- Zero adjustment gas (more than N2 99.9% collected in a gas sampling bag)
- Calibration gas (Air)
- Gas sampling bags

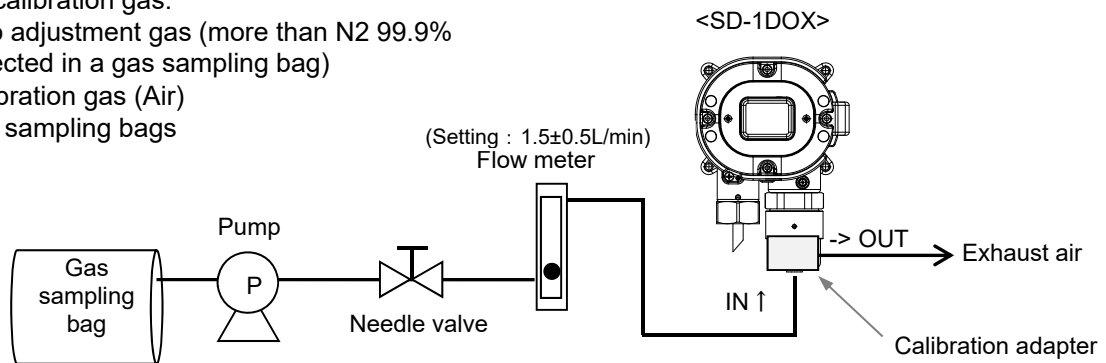

### <Span Adjustment (AIR adjustment) "2-2">

This is used to perform the span adjustment (AIR adjustment).



#### WARNING

When the span adjustment (AIR adjustment) is performed in the atmosphere, check the atmosphere for freshness before beginning the adjustment. If interference gases exist, the adjustment cannot be performed properly, thus leading to dangers when the gas leaks.



#### CAUTION

- Before starting the span adjustment (AIR adjustment), provide the detector with the calibration gas and wait until the reading is stabilized.

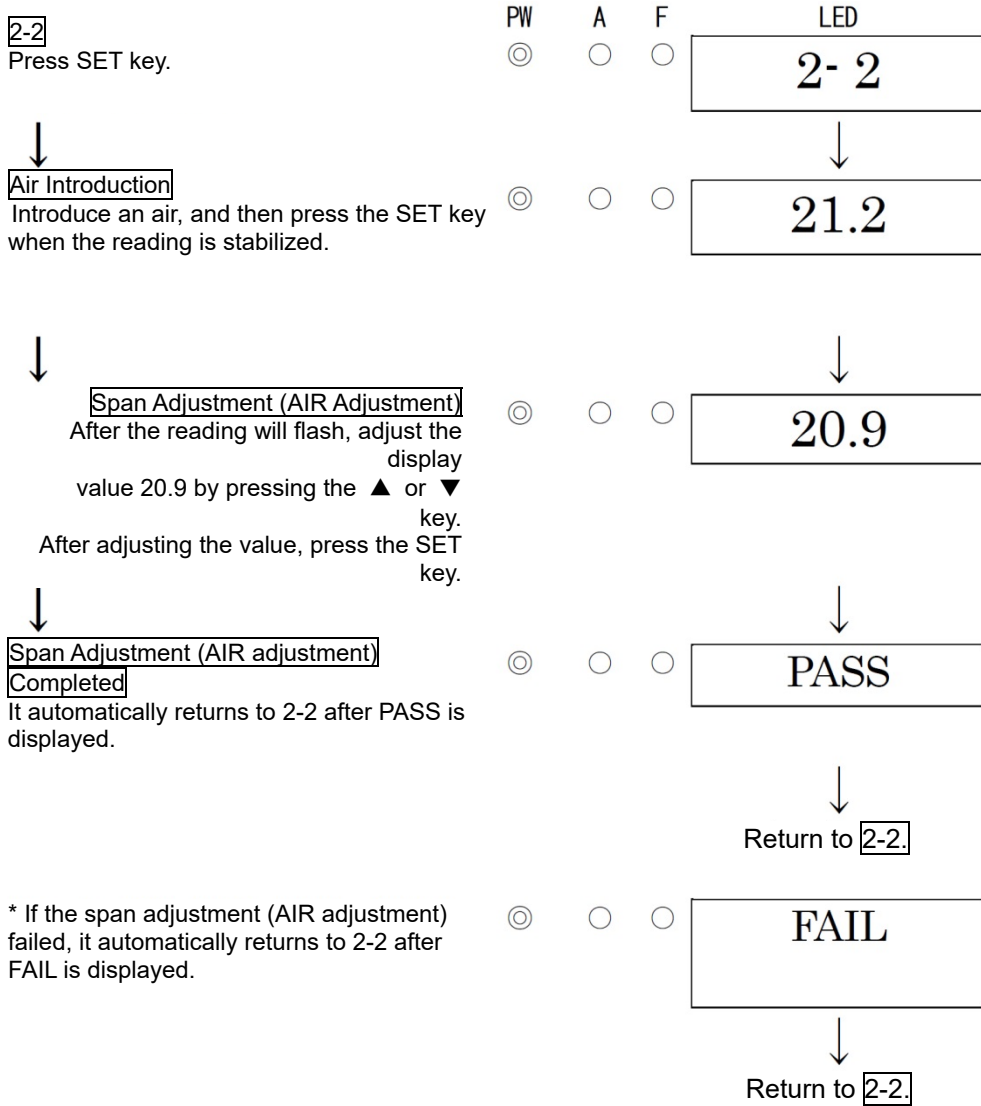

**NOTE**

- If the span adjustment (AIR adjustment) failed since the reading was significantly fluctuated from the introduced gas concentration, it returns to 2-2 after FAIL rather than PASS is displayed. In this case, the span adjustment (AIR adjustment) has not been completed.  
Check if the correct concentration calibration gas has been provided and check the gas adjustment tool for a gas leak. If there are mistakes, perform the span adjustment (AIR adjustment) again.  
If the span adjustment (AIR adjustment) cannot be performed even when there is no mistake or after recalibration, the gas sensor life might have expired. After turning off the power supply, please contact RIKEN KEIKI.

### <Zero Adjustment (N2 adjustment) "2-1">

This is used to perform the zero adjustment (N2 adjustment).

When the detector is used to prevent oxygen deficiency, zero adjustment is not required.

#### NOTE

- Before starting the zero adjustment(N2 adjustment), provide the detector with the zero adjustment (more than N2 99.9vol%) gas and wait until the indicator is stabilized.

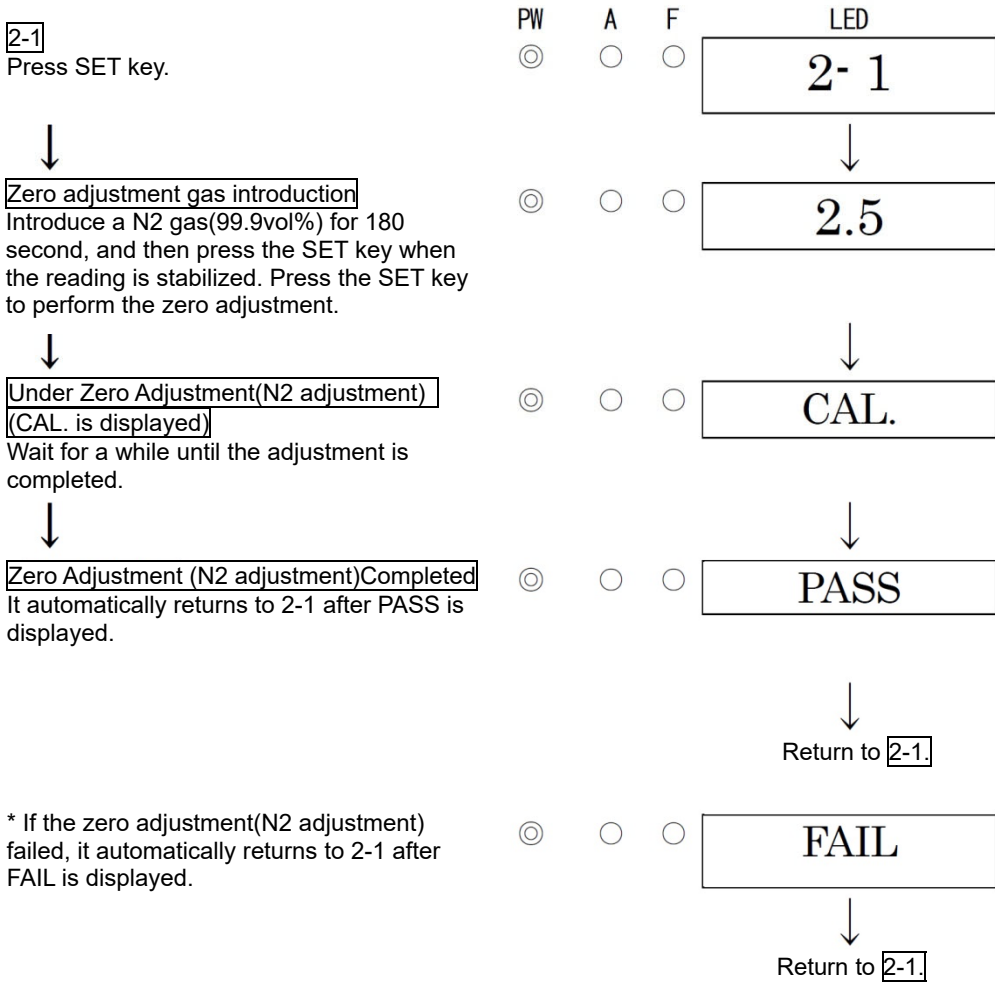

\* If the zero adjustment(N2 adjustment) failed, it automatically returns to 2-1 after FAIL is displayed.

#### NOTE

- If the zero adjustment (N2 adjustment) failed since the zero point was significantly fluctuated from around 0.0, it returns to 2-1 after FAIL rather than PASS is displayed. In this case, the zero adjustment (N2 adjustment) has not been completed.

## 7-4. Parts replacement

### <Sensor Replacement>

Our service engineers need to replace the sensor and perform the calibration.  
Please contact RIKEN KEIKI.

#### NOTE

The calibration using the standard gas is required after the sensor is replaced. Please request it to our overseas sales department or local representatives.

### <Replacement of Regular Replacement Parts>

#### List of recommended regular replacement parts

No.	Name	Maintenance intervals	Replacement intervals (year)	Quantity (pieces/unit)
1	Rubber seal (sensor)	6 months	3 - 8 years	1
2	O ring (sensor / guard)	6 months	3 - 8 years	1
3	Slip ring (sensor guard)	6 months	3 - 8 years	1

- \* The operation must be checked after replacement by a qualified service engineer. For the stable operation of the unit and safety, ask a qualified service engineer to take care of replacement of the parts that operation must be checked. Request RIKEN KEIKI for operation check.

#### NOTE

- The above replacement intervals are recommendation only. The intervals may change depending on the operating conditions. These intervals do not mean the warranty periods either. The result of the regular maintenance may determine when to replace the parts.

---

**8**

---

# Storage, Relocation and Disposal

## 8-1. Procedures to store the gas detector or leave it for a long time

The gas detector must be stored under the following environmental conditions.

- In a dark place under the normal temperature, humidity and pressure away from direct sunlight
- In a place where gases, solvents or vapors are not present
- Storage life of the equipment and sensor are each 3 years and 6 months.

## 8-2. Procedures to relocate the detector or use it again

When the detector is relocated, select a new place in accordance with "4-2. Precautions for installation sites" and "4-4. How to install".

For information on wiring, see "4-6. How to wire". The unpowered time must be minimized when the detector is relocated.



### CAUTION

- When using a relocated or stopped/stored detector again, never fail to perform a calibration. For information on readjustment including a calibration, please contact RIKEN KEIKI.

## 8-3. Disposal of products

When the detector is disposed of, it must be treated properly as an industrial waste in accordance with the local regulations.

## 9

# Troubleshooting

The Troubleshooting does not explain the causes of all the malfunctions which occur on the detector. This simply helps to find the causes of malfunctions which frequently occur. If the detector shows a symptom which is not explained in this manual, or still has malfunctions even though remedial actions are taken, please contact our overseas sales department or local representatives.

## <Abnormalities on Unit>

Symptom/Display	FAULT	Causes	Actions
<u>The power cannot be turned on.</u>	—	The wiring is not correct.	Connect the wiring properly.
		The terminal plate is removed.	Connect the terminal plate properly.
		Abnormalities/momentary blackout of power supply system	Provide the rated voltage. Take measures such as checking or adding the UPS, power supply line filter and insulation transformer.
		Cable abnormalities (open circuit/not connected/short circuit)	Check the wiring of detector and related devices around it.
<u>Abnormal operations</u>	—	Disturbances by sudden surge noise, etc.	Turn off and restart the indicator/alarm unit. If such a symptom is observed frequently, take appropriate measures to eliminate the noise.
<u>Sensor abnormalities</u> E-1	●	The sensor is not connected or improperly connected.	Check if the cable is securely fastened to the terminal plate.
		Faults of the sensor	Replace the sensor with a new one.
<u>System abnormalities</u> E-9	●	The rated voltage is not supplied to the detector.	Check the power supply, and supply the rated voltage. It occurs when the voltage of the power supply falls below 17.0 V.
		Abnormalities of ROM, RAM or EEPROM inside of the detector	Please contact our overseas sales department or local representatives.
		Output signal (4-20mA) does not work correctly.	Check if the cable for external output is correctly connected. (Deterioration of the cable, connection of the host system, etc). If the output is not necessary, connect a resistance to the terminal as mentioned in P19. If it is correctly connected, contact our overseas sales department or local agents because a failure inside this detector might be occurred.



## &lt;Abnormalities of Readings&gt;

Symptoms	Causes	Actions
<u>The reading rises (drops) and it remains so.</u>	Drifting of sensor output	Perform the zero adjustment (or span adjustment).
	Slow leak	A very small amount of the gas to be detected may be leaking (slow leak). Because ignoring it may cause dangers, take a remedial measure, i.e., taking actions the same as those for the gas alarm.
	Environmental changes	Perform the zero adjustment (or span adjustment).
<u>A gas alarm is triggered despite of no gas leak and no other abnormalities at the detection point.</u>	Disturbance by noise	Turn off and restart the detector. If such a symptom is observed frequently, take appropriate measures to eliminate the noise.
	Sudden change in the environment	When the environment (temperature etc.) changes suddenly, the detector cannot adjust to it and is affected by it. In some cases, the detector triggers an indication alarm. Because the detector cannot be used under sudden and frequent environmental changes, any preventive actions to eliminate them should be taken by the user.
<u>Slow response</u>	Deteriorated sensor sensitivity	Replace the sensor with a new one.
	Clogged dust filter	Replace the dust filter.
	Bended, clogged, or leaked suction tube or exhaust tube	Fix the defective parts.
	Condensation is formed inside the suction tube.	Fix the defective parts.
<u>Span adjustment impossible</u>	Improper calibration gas concentration	Use the proper calibration gas.
	Deteriorated sensor sensitivity	Replace the sensor with a new one.

## &lt;Abnormalities of installation environment&gt;

Symptom/Display	FAULT	Causes	Actions
<u>Out of operating temperature range</u> E-27	—	The environmental temperature is out of operating temperature range	Operating temperature range is -10~+40°C. If environmental temperature is out of operating temperature range, countermeasure for adjusting environmental temperature is needed to be considered.

## 10

# Product Specifications

## 10-1. List of specifications

Model	SD-1DOX
Detection principle	Galvanic cell method
Detection gas	O <sub>2</sub>
Concentration display	LED(4digits・7segments)
Detection range	0 - 25vol%
Detection method	Suction method (pour into by external unit)
Flow rate	1.5±0.1L/min
Alarm setpoints	18vol%(L) 【Standard】
Power display	POWER lamp lighting(green)
External output	Gas concentration signal (4-20mA output)
Indicate accuracy* <sup>1</sup> (under an identical condition)	Within ±0.7vol%
Accuracy of Alarm setpoint* <sup>1</sup>	Difference between Alarm setpoint and indicated value of warning alarm are zero.
Response time	T <sub>90</sub> <45 sec.; T <sub>20</sub> <10 sec.* <sup>2</sup>
Alarm-delay time* <sup>1</sup>	By anoxia alarm(Alarm setpoint:18vol%), Less than 5sec. (When introducing 10 - 11vol% gas)(Without piping delay time and communication delay time.)
Equipment drift	±0.5vol% / year* <sup>3</sup>
Gas alarm type	Single alarm(L)
Gas alarm display	ALM lamp lighting(red)
Gas alarm pattern	Auto-recover
Fault alarm・Self diagnosis	System failure (E-9)/Sensor failure (E-1)
Fault alarm display	FAULT lamp lighting(yellow)/Error number display
Fault alarm pattern	System failure : Self-latching Sensor failure : Auto-recover
Transmission scheme	Three-wire analog transmission(in common with power supply<power supply,signal,common>) or Two-wire analog transmission + digital transmission(HART communication)
Transmission specification	4 - 20mADC(linear・load resistance less than 300Ω)
Communication scheme	HART 7 (For maintenance function only)
Transmission cable	CVVS worth of shield cable(1.25mm <sup>2</sup> )・4-core or 3-core CVVS worth of shield cable(2.0mm <sup>2</sup> )・4-core or 3-core
Transmission distance	Less than 1.25km in case of CVVS 1.25mm <sup>2</sup> Less than 2.0km in case of CVVS 2.0mm <sup>2</sup>
Functions	Alarm delay/Suppress/HART communication
Power supply	24VDC±10%
Power consumption	MAX.1.1W
Cabling port	Adapter A<NPT1/2> or adapter B<NPT3/4> or adapter<M20×1.5> or Pressure proof packing gland <G3/4> (Compatible cables φ9.6 - 13.0mm in outer diameter)
Initial clear	Approx.25sec
Operating temperature range	-10 - +40°C(non-rapidly-vary)
Operating humidity range	Less than 95%RH(non-condensing)
Operating pressure range	80 to 120kPa
Storage temperature range	-20 to 40°C
Structure	Wall mounting type

Explosion protected construction	Flame proof structure
Explosion-proof class	II 2 G Ex db II C T6 Gb(ATEX)/ Ex db II C T6 (IECEX)
Dimensions	Approx. 148(W)×205(H)×88(D)mm(projection portions excluded)
Weight	Approx. 2.9kg
Color	Munsell 7.5BG5/2

\*1 In conformity to JIS T8201 2010(Oxygen deficiency indicator)

\*2 At 20°C, T90<20 sec.; at 10°C, T90<30 sec. Otherwise response time is independent of humidity and variation within flow rate range (1.5 ±0.5 L/min).

\*3 At 25°C, 50%RH and constant pressure.

Outline Drawings

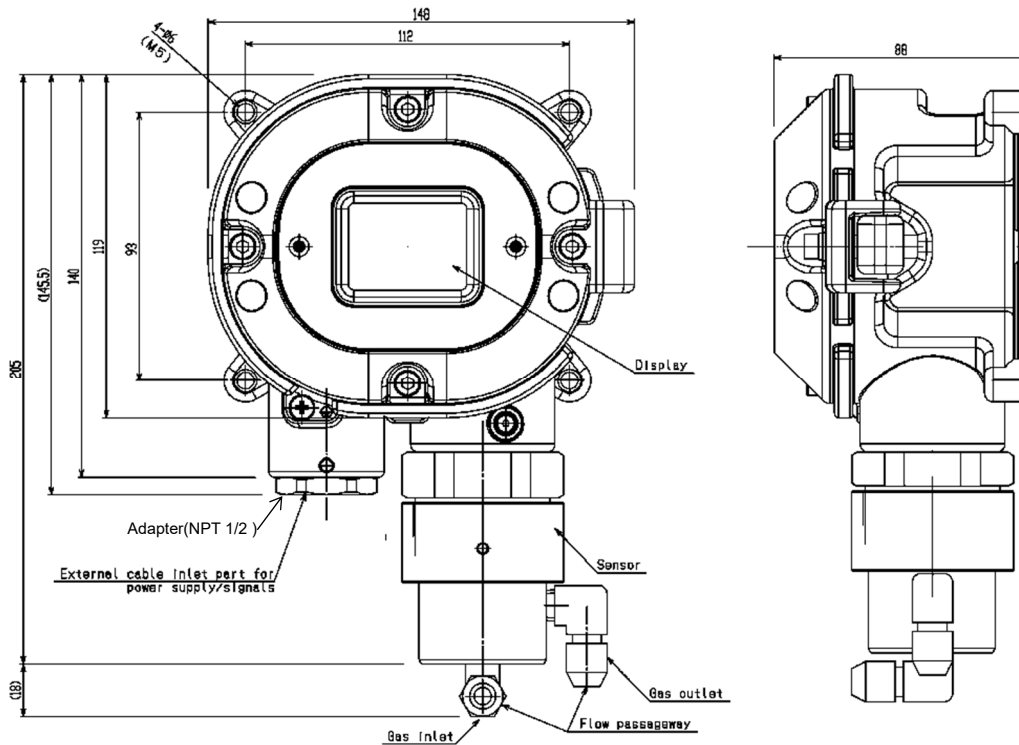

EN 50104 approved option item

No.	Item name	Item sub name	Part number	
1	Calibration cap	SD-1EC/OX	4287 9189 10	Figure 1
2	Dedicated control key	-----	4286 9200 80	Figure 2

Figure 1

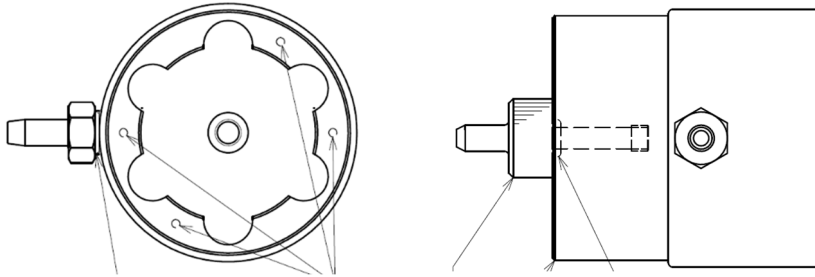
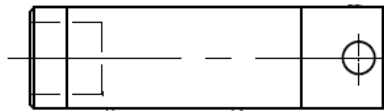

Figure 2



## 10-2. Detection principle

[Detection principle]

A negative electrode of noble metal and a positive electrode of lead are placed in a resin container filled with electrolyte. A part of the container is opened and covered with a barrier. The negative electrode is installed in contact with the barrier. Lead wires are drawn from the positive and negative electrodes to obtain outputs. A thermistor is connected between the lead wires to perform temperature compensation for the sensor outputs.

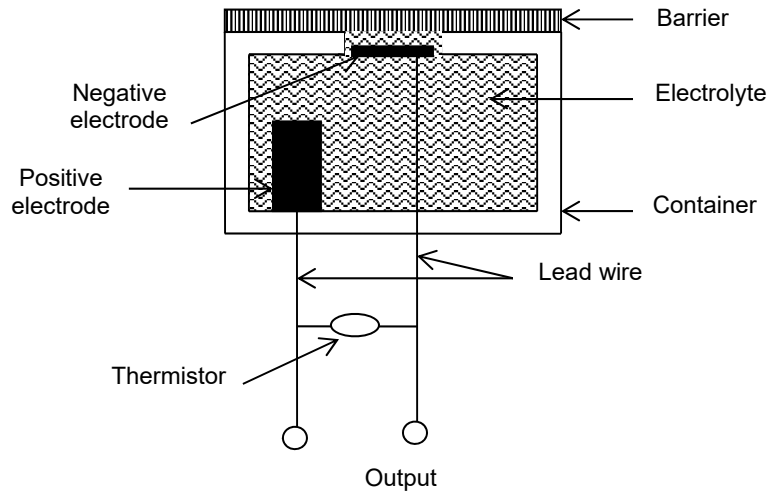

---

# 11

---

## Definition of Terms

Galvanic cell type	This is a principle of the sensor installed in the detector head. See "10-2. Detection principle" for details.
Initial clear	Output from the detector head fluctuates for a while after turning on the power. This is a function to prevent triggering alarm during that time.
Full scale	Maximum value of the detection range.
vol%	A unit used to express the percentage of a specific substance (or gas) in a volume of solution.
Atmosphere	An atmosphere with a temperature within the range of -10 to 40°C and a humidity of 95% RH or less at one atmospheric pressure (1013 hPa).
Calibration	Adjusts the readings to the calibration gas concentration value by using the calibration gas.
Zero suppression	A function to cut off the specific drifting that the sensor has.
Alarm delay time	A function which temporarily suspends activation to prevent a false alarm caused by noise from its outside.
INHIBIT	The gas detection function is temporarily suspended during maintenance etc. of the detector. This is also called "point skip", which has the same function.
HART communication	4-20mA DC signal digitals signalling is superimposed, and is methods that transmit multiple signals.

## Revision History

Edition	Revision	Date issued
0	First edition	12/21/2020
1	Declaration of Conformity	11/12/2021
2	P23, 30, 33, 34, 39 Deleted mention of negative suppression values P29 Change graph of gas concentration and external output P34 Deleted information regarding password entry when transitioning to maintenance mode.	7/29/2022
3	UKEX added, CE Declaration of Conformity changed, UKCA Declaration of Conformity changed added	10/12/2023
4	UKEX and UKCA deleted, Declaration of Conformity updated	5/31/2024



# EU-Declaration of Conformity

Document No. 320CE24094



We, RIKEN KEIKI Co., Ltd. 2-7-6, Azusawa, Itabashi-ku, Tokyo, 174-8744, Japan declare under our sole responsibility that the following product conforms to all the relevant provisions.

Product Name Smart Transmitter/Gas Detector Head  
Model SD-10X, SD-1DOX, SD-1EC, SD-1DEC

Council Directives	Applicable Standards
EMC Directive (2014/30/EU)	EN 50270:2015
ATEX Directive (2014/34/EU)	EN IEC 60079-0:2018 EN 60079-1:2014
RoHS Directive (2011/65/EU <sup>[1]</sup> )	EN IEC 63000:2018

<sup>[1]</sup>Including substances added by Commission Delegated Directive (EU) 2015/863

EU-Type examination Certificate No.	DEKRA 13ATEX0035X
Notified Body for ATEX	DEKRA Certification B.V. (NB 0344) Meander 1051, 6825 MJ Arnhem P.O. Box 5185, 6802 ED Arnhem The Netherlands
Auditing Organization for ATEX	DEKRA Certification B.V. (NB 0344) Meander 1051, 6825 MJ Arnhem P.O. Box 5185, 6802 ED Arnhem The Netherlands

The marking of the product shall include the following:

 II 2 G Ex db IIC T6 Gb -20°C ≤ Ta ≤ +60°C

Alternative Marking: -

Place: Tokyo, Japan

Date: May. 24, 2024

Takakura Toshiyuki  
General manager  
Quality Control Center